

HYMER semi-integrated

HYMER Exsis-t, HYMER T-Class CL, HYMER T-Class SL and HYMER ML-T.



HYMER



The HYMER plant in Bad Waldsee – at the heart of Europe.



Dear Motorhome Owner,

For us, the term “living room on wheels” is not just an empty phrase. HYMER motorhomes deliver exactly what our customers expect from us: excellent quality, a high level of comfort, superior furnishings and optimal safety – and it all comes as standard! After all, we want you to enjoy all the comforts you have at home when you’re on holiday too. That’s why – all rational considerations aside – buying the right motorhome is always an emotional decision too, based on your gut feeling. Erwin Hymer was well aware of this when he launched the first series-produced motorhome in 1971.

And it’s still true today! Across all classes, from the compact semi-integrated to the premium integrated models, HYMER does its utmost not just to satisfy its customers’ wishes and expectations, but to surpass them. As a pioneer in this sector, this is part of our self-image and a debt we owe to the brand’s long tradition. Why not see for yourself and discover the advantages of our wide range of models. This brochure will help you do just that.

Bernhard Kibler

Division Manager HYMER Motorhomes

Contents

Semi-integrated motorhomes.

22



40



58



76



HYMER

Erwin Hymer – the Pioneer
6

Chronicle – a unique success story
8

Why HYMER?
10

The model ranges at a glance
20

Fabric design & carpets
94

HYMER original parts & accessories
96

HYMER Exsis-t

HYMER Exsis-t
22

Standard highlights
24

Living comfort
28

Sleeping comfort
30

Kitchen comfort
32

Bathroom comfort
34

Optional extras
36

Technical data
38

HYMER T-Class CL

HYMER T-Class CL
40

Standard highlights
42

Living comfort
46

Sleeping comfort
48

Kitchen comfort
50

Bathroom comfort
52

Optional extras
54

Technical data
56

HYMER T-Class SL

HYMER T-Class SL
58

Standard highlights
60

Living comfort
64

Sleeping comfort
66

Kitchen comfort
68

Bathroom comfort
70

Optional extras
72

Technical data
74

HYMER ML-T

HYMER ML-T
76

Standard highlights
78

Living comfort
82

Sleeping comfort
84

Kitchen comfort
86

Bathroom comfort
88

Optional extras
90

Technical data
92





Erwin Hymer (* 27th July 1930 † 11th April 2013), a leading figure of the European caravan and motorhome sector.

The Pioneer

Inventor, visionary, entrepreneur – Erwin Hymer wrote camping history by turning his group of companies into a European market leader.

Technical know-how, the pioneering spirit of the entrepreneur and a healthy dose of ambition and hard work – all of these were typical of Erwin Hymer, who died in April 2013. From small beginnings, he created a group of companies which now ranks among the leading motorhome and caravan manufacturers in Europe and is active worldwide.

As a young engineer, Erwin Hymer followed his parents' calling and began working in his father Alfons' repair shop in the southern German town of Bad Waldsee in 1956. Just one year later, he developed the first caravan – the original "Troll" – in collaboration with the engineer Erich Bachem. And thus began a new era! The next decisive step came in 1971 with the launch of the first HYMER motorhome – a key milestone in our long corporate history.

The past 57 years have seen a wide variety of different series, models and layouts. Many of the motorhomes and caravans set standards and ushered in new trends – especially in terms of technology, comfort, quality, design and safety. For our founder Erwin Hymer, incorporating customers' wishes into the development of new and improved vehicles was always a matter of principle.

As a result, the concept of the mobile home has always been inseparably linked with the name HYMER. And the passion and professionalism that goes into the development and construction of our vehicles communicates itself to our customers. For decades, Erwin Hymer's inventiveness and ceaseless creativity has shaped the entire industry. His whole life's work provides us with a model for future corporate decisions.



Bad Waldsee

Visit the Erwin Hymer Museum and discover the world of motorhoming and the greatest routes of all time.

www.erwin-hymer-museum.de

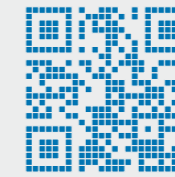

A unique success story

The history of the HYMER motorhome.

The development of the integrated Hymermobil at the beginning of the 70s ushered in a new era in the history of motorhoming. This year will see the 150,000th HYMER motorhome leave the production line. From the legendary B-Class or the luxurious S-Class to the lightweights of the Exsis series or the colourful variety

of semi-integrated models – many vehicles from these model ranges have been crowned with major awards over the years. This chronicle sketches the key stages in the remarkable success story of the Hymermobil.

1923



1957



1961



1971



1976



1978



1981

The beginning of a unique success story.

Alfons Hymer begins production of agricultural vehicles.

Erich Bachem ("ERIBA") and Erwin Hymer build the original "Troll", the first caravan.

The first hand-built HYMER motorhome, the Caravano, makes its debut.

The first Hymermobil is built and presented at the Caravan Salon.

The Hymermobil 521 with fold-down double bed in the cab becomes a bestseller.

The innovative PUAL wall structure is developed and proves its stability.

The HYMER B-Class is introduced and develops over the following years into Europe's most popular motorhome.



1986

HYMER becomes the first manufacturer to grant a 6-year water ingress warranty on its motorhomes.



1995

HYMER presents the new S-Class and becomes the first company in the industry to be certified according to ISO 9001 on the strength of its high product quality.



2004

In October, the 100,000th Hymermobil rolls off the production line in Bad Waldsee.



2007

HYMER's 50th anniversary is honoured with an anniversary edition of the B-Class SL in gold.



2011

Opening of the Erwin Hymer Museum opposite the company headquarters in Bad Waldsee.



2012

Lightweight design from Bad Waldsee – HYMER puts its stamp on the 3-ton class and sets new standards within the industry.



2014

Europe's leading manufacturer produces the 150,000th HYMER motorhome.

Unique to HYMER:
the symbol for top quality
you can see and feel in every
HYMER motorhome.



Why HYMER?

The name HYMER is synonymous with motorhoming.

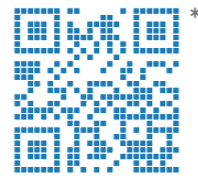

*www.hymer.com

There are many important criteria to consider when buying a motorhome. After all, it's an investment you expect to benefit from for years or even decades to come, enhancing your leisure time and holidays and bringing you freedom and independence. So who better to turn to for information than a renowned supplier and world market leader with a wide selection of vehicle types? All products are developed on the principle that HYMER customers are entitled to expect a high-quality vehicle with superior comfort, and one which represents a worthwhile economic

investment. In addition, all HYMER motorhomes are equipped with extensive safety features as standard. The specialists from Bad Waldsee pride themselves on setting ever new standards, especially – though not only – in terms of weight or PUAL (polyurethane/aluminium) construction. What's more, HYMER customers have access at all times to a comprehensive range of services. For all these reasons, when it comes to choosing a motorhome, you need look no further than this premium product from Bad Waldsee!



We are always close at hand – as service providers and as people who share a common passion.

High-tech body

Every HYMER is a masterpiece of engineering.

Besides their innovative safety features and high level of traveling comfort, our motorhomes have a key advantage that makes for excellent value retention: their durable high-tech bodywork. Every Hymermobil component is the product of years of development and testing drawing on state-of-the-art material science

and engineering. Thanks to the integral insulation concept and sophisticated heating and ventilation system, our vehicles are equipped for all weathers and suitable for year-round use. That puts us one step ahead of other motorhome manufacturers!



Top marks

Each Hymermobil is subjected to various endurance tests, e.g. extreme cold. It then undergoes further detailed testing by our staff.



Double glazing

The inclusion of high-quality framed windows with acrylic double glazing as standard is a further HYMER milestone.



Robust coating

Corrosion, cold and material fatigue don't stand a chance in the Hymermobil thanks to the GRP roof coating, floor and other components. Protection against grit and salt is likewise guaranteed.

Weight saving thanks to lightweight construction

The PUAL wall design guarantees a perfect interior climate and good heat insulation, and the innovative lightweight construction technique as a whole has many advantages. Gapless elastic bonding ensures that the walls and roof are sealed together tightly, making them both waterproof and capable of withstanding extreme stresses. And just to be on the safe side, HYMER offers a six-year water ingress warranty.

Winter resistance

For carefree travel even in cold and snowy conditions.

All our Hymer motorhomes are factory-fitted with winter-proof features, making them suitable for year-round use. Clever climate control solutions such as the insulated service installations and tanks, the sophisticated heating and ventilation system and

HYMER's unique bonding technology make them fit for all weathers. That way you stay warm as toast even when it's icy outside. Thanks to the winter-proofing features, your pipes and tanks can't freeze – and you save gas thanks to perfect heat insulation.



Truma heater

Installed as standard, the 6,000W Truma Combi 6 heater easily maintains a cosy temperature throughout the interior even when it's freezing outside.



Central heating

Its central location under the seating area means that the heat is distributed optimally throughout the vehicle. Numerous heating outlets ensure a pleasant temperature throughout the living area.



Cosy cab

The front windscreen too is supplied with plenty of warm air. That way the entire cab and living area stays at a pleasant temperature even in the cooler months.



Winter ventilation

Winter air vents are provided in the windows and seating areas and in the kitchen. These ensure efficient air circulation and an optimal climate inside the vehicle.

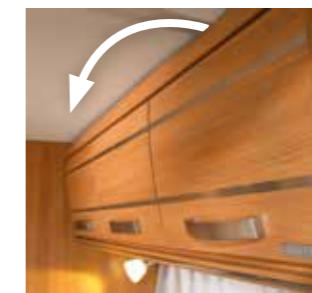

Rear ventilation

All overhead storage cupboards have a void at the back through which warm air can circulate freely, thus avoiding unwanted condensation.

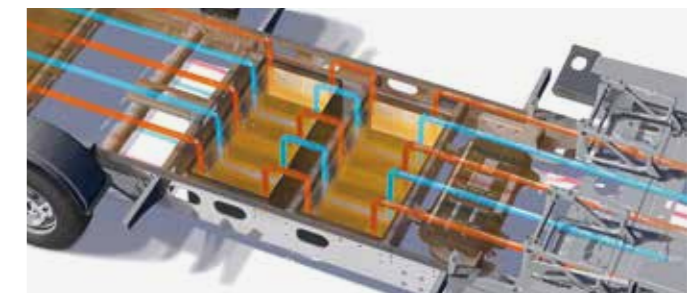

The vehicle for winter sports fans

Our motorhomes offer a hassle-free all-round package for winter sports enthusiasts: insulated service installations and tanks, heated dashboard and exterior locker compartments, winter air vents in the windows and seating areas and a warm air supply under the cab seats. As for the exterior, the GRP floor provides effective protection against grit and salt.

Every modern convenience

What more could you wish for?

High standards have always been associated with HYMER and its customers. So it's no wonder that even the standard equipment of our vehicles includes a number of high-end comfort features – not to mention the wide choice of high-quality extras. But comfort isn't just about equipment. Whether or not you feel at home

in a motorhome is determined by fundamental factors such as spatial effect and proportions, freedom of movement and the user-friendliness and functionality of the individual elements. HYMER scores on all these fronts – you can just feel the quality.



Power saving

HYMER living areas are notable for their warm atmosphere. Pleasant illumination is ensured by the large windows in the daytime, and by the standard integrated LED lighting system in the evening.



Adaptable bathrooms

Whether you opt for the variable bathroom, variable premium bathroom or open bathroom with separate shower: all offer remarkable freedom of movement.



Culinary pleasures

No culinary wishes go unfulfilled in a HYMER kitchen thanks to top-quality fittings, an ergonomically designed workspace and plenty of storage for provisions and cooking utensils.



Healthy sleep

A good bed is the foundation of healthy, restorative sleep. That's why every Hymermobil comes with modern multi-zone cold-foam mattresses in the sleeping area.



Stowage space galore

The stowage facilities combine quantity and quality to a unique degree. From the extra-large garages to the many storage compartments and overhead storage cupboards – not an inch of space is wasted.



Secure storage

All kitchen drawers are equipped with ball bearings for a smooth action and feature a Servo-Soft closing mechanism and fasteners to prevent them from opening and rattling while the vehicle is in motion.

Feel-good design

A higher-quality interior.

What HYMER offers is more than just a living environment: it's a veritable living experience! The perfect coordination of the components is visible at a glance. The design is attractively contemporary, geared towards international trends but always customer-oriented. It brings together technical functionality and a

feel-good ambience. All upholstery is designed by HYMER's textile designer and produced in our own sewing workshop for guaranteed top quality. In all our furnishings, we pride ourselves on using premium materials which are pleasant to the touch.



Design & quality

The intelligent light construction concepts of our motorhomes are a perfect combination of contemporary design and top quality. New design trends can be readily adopted without compromising the traditional cosy look and stylish ambience of our vehicles. The kitchens are extremely easy to clean and boast modern worktops and fittings in an attractive household style.



Upholstery & fabrics

Only textiles from renowned manufacturers are used in our sewing workshop. All fabrics are stain-protected and meet the relevant standards for UV stability, colour and hot light fastness.



Handles & fastenings

The easy-grip, ergonomic real metal handles are extremely durable. The HYMER closure system guarantees secure locking of every cupboard door.



Colours & materials

Colours, materials and finishes are crucial to the spatial effect. A balanced, warm colour scheme creates a pleasant atmosphere you'll want to spend time in.

Maximum safety

Prepared for all eventualities.

Driving safety and comfort have reached an extremely high standard in the automotive sector. That same standard is applied to each and every HYMER motorhome. Top safety standards are defined at the development stage and successfully implemented – from the vehicle body to the intelligent electronic safety systems.

These serve to assist driving and acceleration, e.g. on difficult terrain, and to ensure better roadholding. They prevent the vehicle from skidding or swerving and the wheels from jamming in critical situations. They also assist driving and manoeuvring in mountainous areas, on uphill and downhill stretches.

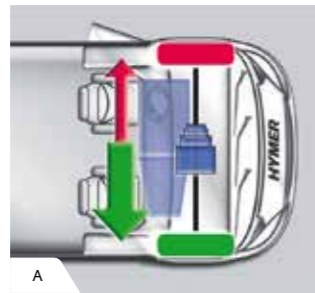

Standard driving safety

The excellent driving comfort of HYMER motorhomes is complemented by an extremely comprehensive standard safety package featuring driver and passenger airbags, ABS, TCS und ESC incl. Trac-

tion+ (A). Added safety and convenience is provided by electrically adjustable and heated wing mirrors, a daytime running light and hill holder and hill descent assist facilities.



All-round view

The high, panoramic windscreen, extra-large side windows in the cab and standard daytime running light ensure safe, all-round visibility.



Weatherproof on tour

In integrated motorhomes, the three windscreen wipers and wide wiper field guarantee a clear view of road edges and crossroads.



Excellent roadholding thanks to AL-KO frame

The AL-KO lightweight technology cuts down on weight without compromising on stability. That way, motorhomes on a Fiat chassis can have a bigger payload. The lower centre of gravity improves driving stability and the broad-gauge chassis ensures better roadholding, while the torsion bar suspension and high-performance wheel shock absorbers guarantee you a smooth ride equal to that of a car.

Innovation

Always a HYMER's length ahead.

As a pioneer of the motorhome sector, HYMER has developed a number of revolutionary innovations over the past few decades which have had a lasting influence on motorhoming culture. The crank-handle rooflight, the wheel arch refrigerator, a specially developed HYMER headlight and the fold-down bed

are just a few examples. Our future agenda will focus more than ever on the ecological aspect, particularly with regard to maximising energy efficiency. HYMER has long set standards in this field, achieving drastic weight reductions thanks to innovative materials and the use of state-of-the-art LED lighting technology.



29 × promobil
Motorhome of the Year
1987 – present



Travel safety

Safety should be more than just an aspiration. That's why HYMER already fulfils all the statutory safety requirements with its standard safety package.

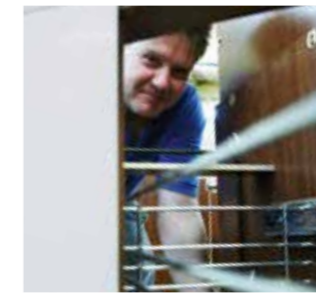

Made by HYMER

High-quality furniture design is a HYMER tradition. 90 % of all furniture parts are made in our own factory – with modern technology and materials. The fittings are household standard.



Spacious interior

HYMER is the inventor of the fold-down bed in the semi-integrated motorhome. The sleeping area in the roof takes nothing away from the living area and leaves scope for a creative layout.



Magic weight

This is standard with the "inventor of the 3-ton class": the Exis-t, ML-T and Exis-i all weigh in below the magic limit of 3.5 tons for example, even with a large payload. Not only does this save fuel: in some countries, it also avoids higher toll fees. Another plus is that vehicles of this weight can also be driven with a category B driving licence.

Added value for all

Value retention and economy as standard.

HYMER customers not only get to enjoy their vehicles for longer: they also get more out of them. Take the comfortable warmth combined with low heating costs, for example – all thanks to first-class insulation. Or the advantages when it comes to road tolls and taxes: thanks to the innovative lightweight construction

of our motorhomes, you not only save weight, but money too. In short, each Hymermobil represents an extremely worthwhile investment – not to mention the unique return you won't get anywhere else, i.e. the unforgettable holiday experiences you can enjoy where and whenever you choose.



Value for money

HYMER motorhomes offer a good price/performance ratio across all vehicle classes and model ranges. With our vehicles, you really do get what you pay for.

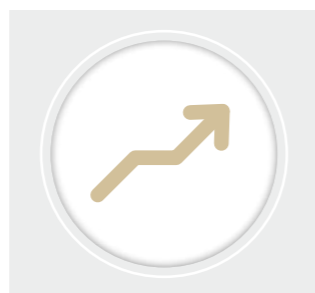

Lasting value

The value retention of HYMER motorhomes is legendary. Even after several years, the vehicles remain reliable travelling companions and fetch an accordingly high price on the market.



Top service

A first-class, reliable service is central to the HYMER ethos. The dealer and customer service network with qualified workshops throughout Europe is unrivalled within the industry.



More equipment

Hymer motorhomes leave no wish unfulfilled and offer more in the standard version than other manufacturers do in their customised vehicles. We never compromise on performance for the sake of cosmetic price reductions.



Efficiency savings

Savings on gas and electricity mean lower costs and a longer range. The first-class insulation, high-tech body shell and heat insulation therefore pay for themselves within a short time.



Quality controls

From the drive to the bodywork to the smallest accessory: all Hymermobil components are impeccably engineered, and are subject to the strictest material tests and quality controls.

The world of HYMER

For all your motorhoming needs.

A Hymermobil leaves no wish unfulfilled. And HYMER leaves nothing to chance when it comes to after-sales service either. We make sure our customers get exactly the help they need. In addition to exemplary support and a dense dealer network, you can always draw on the active and well-organised HYMER com-

munity. And that goes not only for the purchase itself: our service extends well beyond, with help and advice in case of any necessary repairs and tips and suggestions regarding original parts and accessories. That way new customers often become true "Hymerists" in no time.



On your doorstep

Always there for you in your vicinity – thanks to the extensive HYMER dealer network, you can get rapid assistance and competent advice without having to travel long distances.



HYMER on the internet

At www.hymer.com, you will always find all the latest information on our series and models, along with everything you need to know about our company and the service we offer.



HYMER on Facebook

We already have nearly 20,000 friends on our Facebook page, and the number is rising daily. Why not join them?
www.facebook.com/hymerAG

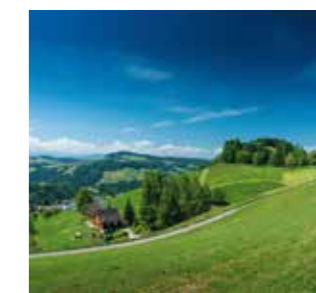

Top travel tips

A new country to discover each year with HYMER. Amazing travel impressions, interesting, varied routes and destinations – all compiled especially for you.



HYMER customer card

The HYMER customer card gives our customers access to exclusive premium offers and numerous other advantages. It also entitles you to receive an informative customer magazine.



Supply network

If a part is needed at short notice, our 450-plus dealers around the world are ready to step in. That way we can make sure the right part gets to the customer.



Come and see us!

You are more than welcome to take a tour of our motorhome and caravan production facilities. You can find the dates of our factory tours with details of how to book on our website.



Rent-a-HYMER

The world's your oyster with HYMER Rent – your motorhoming partner. You can find your ideal local outlet at www.hymer-rent.de.

Comfort levels for all tastes and budgets





The semi-integrated motorhomes at a glance.

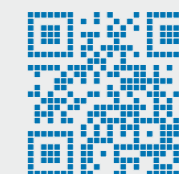

Take a peek behind the scenes at HYMER with our informative factory tour.

www.hymer.com/tour



Model range	HYMER Exsis-t	HYMER T-Class CL	HYMER T-Class SL	HYMER ML-T
Profile	Semi-integrated models in the 3-ton class with high level of comfort	Roomy semi-integrated model with high level of comfort	Exclusive semi-integrated model with double floor	Premium semi-integrated model on Mercedes base
Chassis				
Over 3,500 kg	—	✓	✓	✓
Below 3,500 kg	✓	✓	✓	✓
Length (in metres)	5.95 – 7.15	6.69 – 7.49	6.99 – 7.79	6.98
Width (in metres)	2.22	2.35	2.35	2.22
Height (in metres)	2.77	2.90	2.90	2.90
Berths	2 – 3	2 – 5	2 – 3	2 – 3



* = new

promobil

Motorhome of the Year 2014:
1st place in the category
"Semi-integrated up to EUR 50,000"



The HYMER Exsis-t

Carefree travel – wherever you're heading.

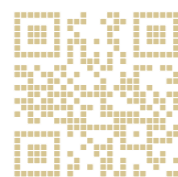

The new Exsis-t is the next episode in the success story of our lightweight motorhomes. With a laden weight of less than 2,700 kilos this model range is a near-perfect combination of lightweight construction and comfort. The drive-ready Exsis-t 414 weighs in at just 2,630 kilos unladen, for example. That means it can take plenty more weight without exceeding the important 3.5-ton limit, thereby setting new standards in the semi-integrated class. Specially developed materials, state-of-the-art pro-

duction techniques, lightweight GRP floors, AL-KO lightweight frames and the brand-specific PUAL body shell all combine to save a good deal of weight, without compromising in any way on the equipment features: interior LED lighting, garage doors on both sides and multi-zone cold foam mattresses come as standard along with the comprehensive safety package including airbags, ESP, Hill Holder and much more.

Profile *
Weight: 3,500 – 4,500 kg
Length: 5.95 m – 7.15 m
Width: 2.22 m
Height: 2.77 m
Berths: 2 – 3

HYMER Exsis-t highlights

A vision becomes reality.

Seitz-S7 framed windows

All tanks and service installations insulated and heated

Light, slender and manoeuvrable thanks to an outside width of 2.22 m

Large garage doors on both sides

GRP lightweight floor construction with styrofoam insulation

AL-KO lightweight frame with independent suspension

Slimline in shape but lavishly appointed: The HYMER Exsis-t offers you a range of high-end features as standard. That way you can enjoy first-class driving and living comfort – and it's all included in the unladen weight of less than three tons.



Tailor-made undercarriage

The specially developed AL-KO lightweight frame with independent suspension forms the perfect basis for the motorhome body. Its optimally positioned wheelbase ensures equal weight distribution, even when the vehicle is fully loaded.

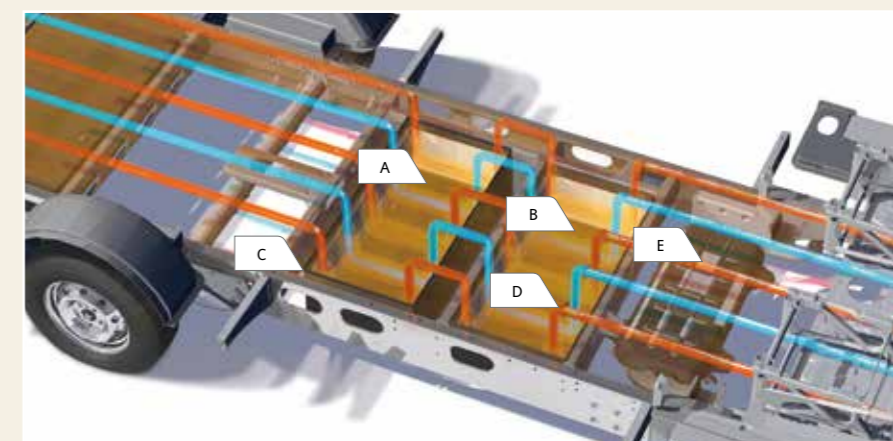

Heated undercarriage

The floor conceals the fresh water (A) and grey water tank (B) in insulated trays (C), which have hot air flowing through them (D). All the plumbing and wiring (E) is accommodated in

the heated living space, safe from frost. The numerous, optimally distributed hot air outlets guarantee perfect climate control throughout the whole vehicle.



Lasting protection from below

The indestructible GRP underbody makes the vehicles practically immune to weather damage. Stone damage, grit and dirt are likewise kept at bay – a solid foundation for the entire service life of your motorhome.

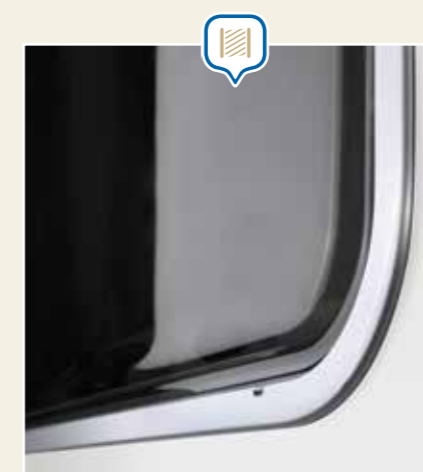

Great view, no thermal bridges

The high-quality Seitz-S7 framed windows are fitted with acrylic double glazing for optimal thermal insulation. The powder-coated aluminium frame is particularly lightweight and sturdy and is likewise equipped with an insulating layer to protect against thermal bridging.

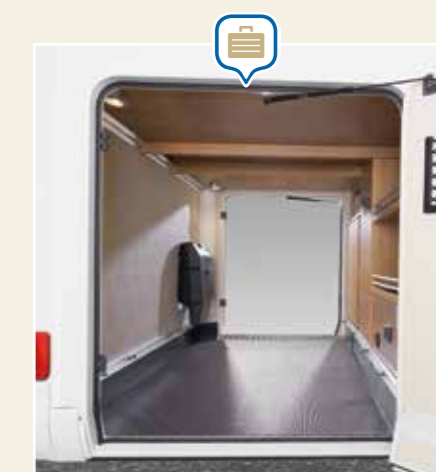

Large garage doors

The garage comes with full-height doors on both sides of the vehicle as standard. That way, it can be loaded from both sides and luggage remains accessible from the outside at all times. And you can't grumble at the storage capacity – a full 350 kilos!

* Maximum values. Further technical data can be found in the layout overview on page 38/39.

The Exsis-t comes with a whole range of attractive standard highlights which not only improve safety but guarantee exceptional comfort for a cosier environment. That way, travelling becomes a uniquely enjoyable experience.

Further standard highlights:
www.hymer.com/exsis-t/standard

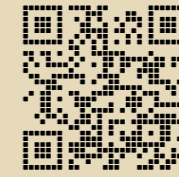

Handy exterior light

The high-power LED awning light with rain deflector comes as standard. It lights up a wide area outside the entrance door so you can exit the vehicle safely in the dark.



Easy entry

The electric step at the entrance to the living area ensures easy access.



More headroom

The large clear glass rooflight (40 × 40 cm) above the rear beds comes with mosquito nets and blackout blinds fully integrated into the frame. That way the rooflights barely encroach on the interior, ensuring full headroom.

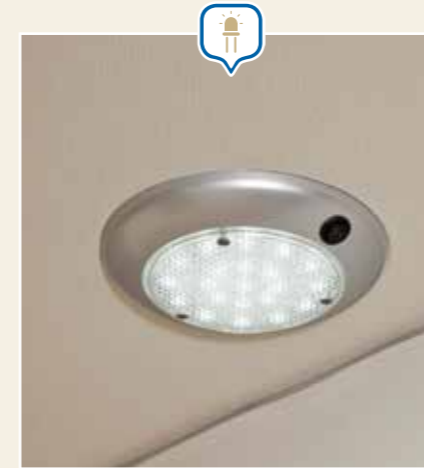

Energy-saving LEDs

The interior lighting throughout the vehicle features LED technology as standard. This cuts energy consumption by 3/4 and gives you hours of extra battery life. Since LEDs don't get hot, this also improves fire and accident safety.

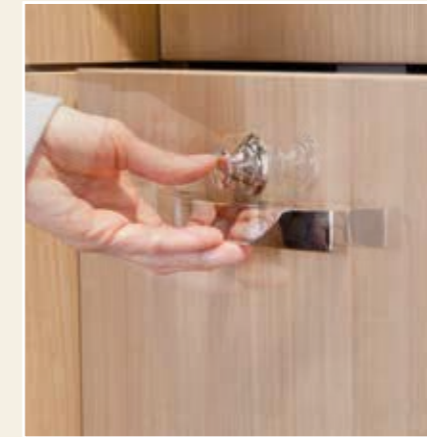

Safe handling

All kitchen drawers are equipped with ball bearings for an ultra-smooth action. They feature high-quality Servo-Soft closing and one-hand push-locks which prevent the drawers from opening and rattling while the vehicle is in motion.

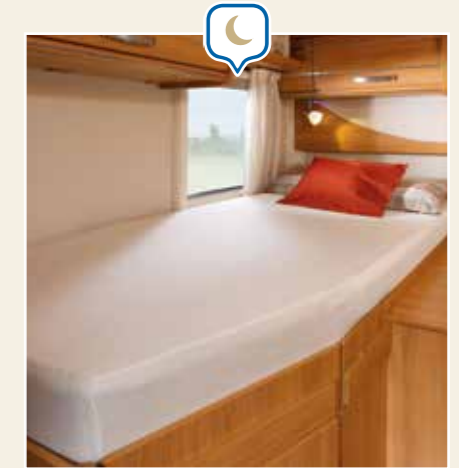

Superior sleeping comfort

All beds are equipped with high-quality multi-zone cold foam mattresses that provide the right support for all areas of the body. Breathable mattress toppers in the rear ensure good ventilation.



Truma Combi 6 heater

Installed as standard, the 6,000W Truma Combi 6 heater easily maintains a cosy temperature throughout the interior even when it's freezing outside. Its central location under the seating area means that the heat is distributed optimally throughout the vehicle.



Smooth transition

The floor echoes the smooth transition between the cab and the body of the vehicle. The floor area between the driver and front passenger seat has a reinforced, non-slip bridge allowing easy access to the cab.

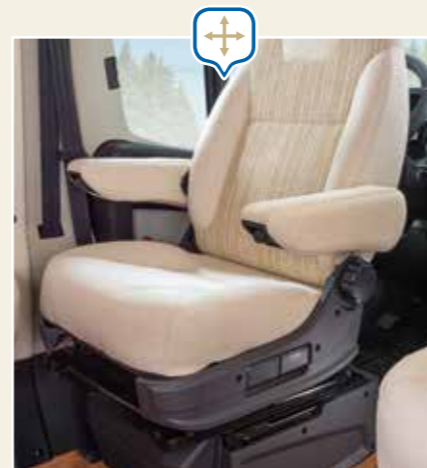

Handy multi-taskers

The swivelling and height-adjustable lounge seats in the cab are fully upholstered in the same fabric as the living area. Their exceptional seating comfort and large, tiltable arm rests are ideal for settling down to watch TV and for relaxed driving.



Watertight installation

The shower tray and walls are joined via a shell structure so there are no gaps for water to escape through. This leak-tight construction makes it possible to minimise the use of silicone for sealing.

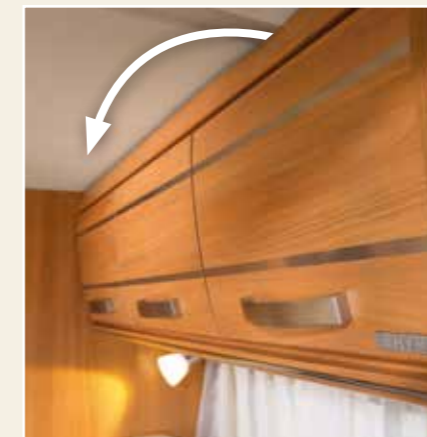

Rear ventilation

All overhead storage cupboards have a void at the back through which warm air can circulate freely. That way major temperature variations and unwanted condensation in the interior can be avoided.

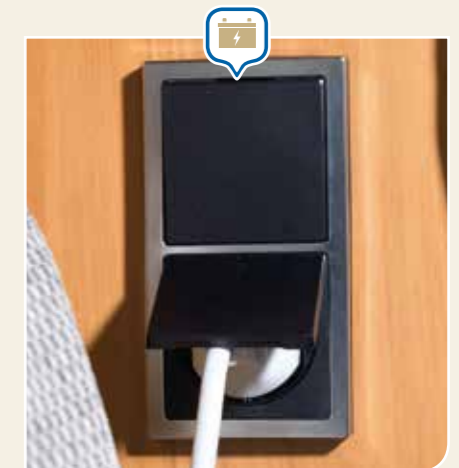

Plenty of sockets

Four 230V and two 12V sockets provide plenty of power for your appliances. The seating area, bathroom and kitchen have points for 230V appliances, while 12V appliances can be plugged in at the TV point and dashboard.

Illustrations for example purposes only.



Living comfort

Ample space, light and quality of life

1 First-class seating

Harmonious interior with warm Trentino pear wood furniture finish and Castello fabric design – seen here in the Exsis-t 588.

2 Warm and cosy

The spacious L-shaped seating area in the Exsis-t 474 creates a warm and cosy atmosphere you can feel at home in – featuring the new Varuna fabric combination.

3 Home from home

The optional L-shaped seating area in the Exsis-t 588 lends a cosy, even homely look to the whole interior thanks to the new Cremissimo fabric design.

4 Lounge feeling

The cab is perfectly integrated into the living area in the Exsis-t for an authentic “lounge feeling”. The B-pillars are additionally upholstered and the overhead storage cupboards extend over the driver and passenger doors – seen here in the Exsis-t 414.

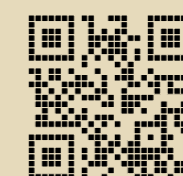

Step aboard the Exsis-t with a virtual tour:

www.hymer.com/exsis-t/360



1



2

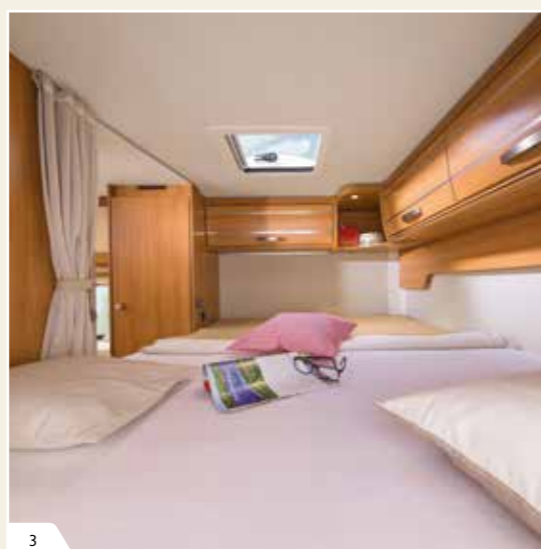

3



4

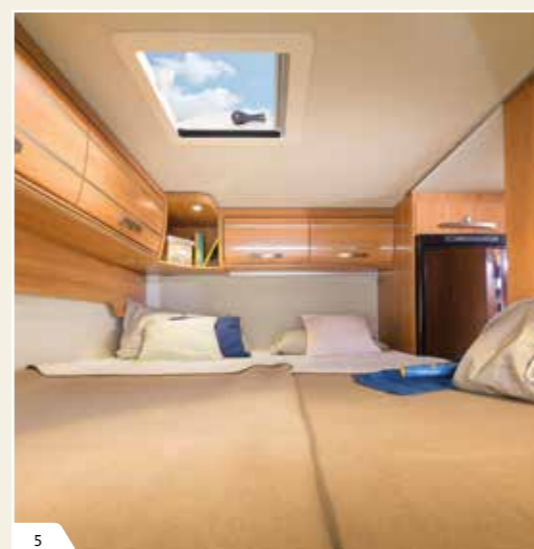

5

Sleeping comfort

Dream interiors where the last thing you'll want to do is sleep.

1 Easy access

The sleeping area of the Exsis-t 588 has a connecting cushion between the mattresses as standard. This model can also be supplied with low-level single beds on request.

2 Extra sleeping space

Thanks to an optional additional cushion, the single beds can be joined together to make an extra-large double bed. A ladder is provided for easy access.

3 Double delight

Despite its compact overall length of 5.95 metres, the Exsis-t 414 boasts a full-size double bed measuring 200 × 150/135 cm.

4 Tidy storage

The 40 cm wide wardrobe in the front entrance area of the Exsis-t 688 offers plenty of space for your holiday wear.

5 Romantic interludes

Measuring 200 × 148 cm, the generous double bed at the rear of the Exsis-t 564 offers plenty of scope for romantic moments.

Kitchen comfort



1

Everything the creative cook desires.



2

1 Generous kitchen area

A large side kitchen is a standard feature of the Exsis-t models 414, 474 and 588. The readily accessible overhead storage cupboards and large, flexibly partitioned drawers make life a whole lot easier when it comes to kitchen chores.

2 Extendible work surface

The worktop can be extended at a stroke to give you more space, thanks to this clever design.

3 Jumbo refrigerator

Jumbo refrigerator (150 litre) with separate freezer compartment – available on request in all Exsis-t models (except Exsis-t 414 and 474, which have a 142-litre Smart-Tower refrigerator).



3

Bathroom comfort

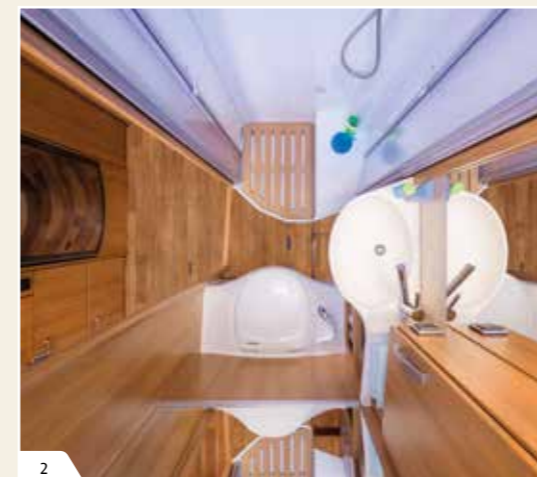

1 Ample space

The extremely roomy comfort bathroom not only boasts a separate shower with fixed walls but also allows plenty of space in front of the washbasin.

2 Superior sanitation

The high-quality bench toilet in the Exsis-t 588 has a comfortably wide seat and is relatively simple to clean.

3 Exquisite washbasin

The washbasin in exquisite Cool Glass not only looks great, but also slides out conveniently as needed – available in the Exsis-t 414 or 474.

4 Generous shower space

The retractable washbasin and swivelling toilet seat create a generous shower space as if by magic, despite the vehicle's compact dimensions.

Extra comfort to order

Want to add a more personal touch of class to your HYMER motorhome? There is a wealth of attractive extras available to customise your van. Below are just a few of them – your HYMER dealer will be happy to provide details of the full range.



1



2



3



4

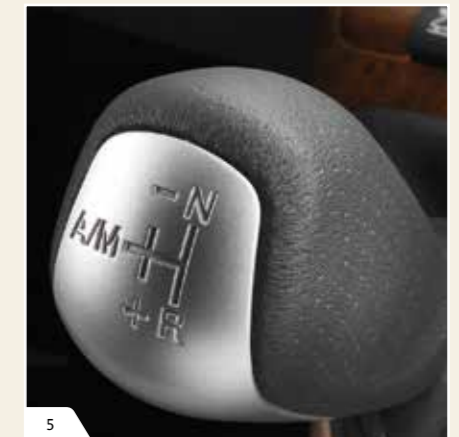

5



6

1 Distinctive lightness

The high-quality aluminium rims lend the vehicle extra individuality and class on the outside too. Their low weight not only increases the payload reserves but also improves the effectiveness of the suspension for an easier drive.

2 Optimal leak-tightness

The vehicle roof is made from robust aluminium and has no longitudinal seams for water to penetrate through from above. The GRP coating provides additional weather and hail protection, preventing mechanical damage to the roof surface.

3 Plenty of chilling space

The large refrigerator comes as standard. With a capacity of 150 litres and a separate freezer compartment, it can be relied on to keep even large quantities of groceries fresh (depending on the layout).

4 High-tech in the kitchen

The Thetford hob and oven combination offers home-from-home cooking convenience. From baking to grilling to cooking, it caters to every culinary desire – and the individual components are very easy to clean.

5 Relaxed driving

The Fiat Comfort-Matic combines the precision of a 6-speed gearbox with the comfort of an automatic. The gears can be changed either manually, by tipping the selector lever, or fully automatically – with optimised function and fuel consumption.

6 Fresh air guaranteed

The powerful "Fantastic Vent" electric ceiling fan keeps steam and kitchen odours at bay. That way the air inside the vehicle stays nice and fresh – even when it's too chilly outside to open a window.

Illustrations for example purposes only.



Layouts and technical data

The HYMER Exsis-t models at a glance.

Technical data

Chassis



Overall length (cm)	595	650	670	695
Overall width (222 cm)	✓	✓	✓	✓
Overall height (277 cm)	✓	✓	✓	✓
Headroom in living area (198 cm)	✓	✓	✓	✓
Mass in running order approx. (kg)	2,630	2,750	2,790	2,800
Payload approx. (kg) / O	870 / 1,220	750 / 1,100	710 / 1,060	700 / 1,050
Max. permissible laden mass (kg) / O	3,500 / 3,850	3,500 / 3,850	3,500 / 3,850	3,500 / 3,850
Berths + O	♣♣+♣	♣♣+♣	♣♣+♣	♣♣+♣

Overall length (cm)	695	715
Overall width (222 cm)	✓	✓
Overall height (277 cm)	✓	✓
Headroom in living area (198 cm)	✓	✓
Mass in running order approx. (kg)	*	2,860
Payload approx. (kg) / O	* / *	640 / 990
Max. permissible laden mass (kg) / O	3,500 / 3,850	3,500 / 3,850
Berths + O	♣♣+♣	♣♣+♣

All technical data can be found in the current motorhome price list.

O = Optional extras
* Data not yet confirmed on going to press.

Standard chassis:
Fiat AL-KO Ducato



In HYMER motorhomes the overall length and width, unladen and laden mass are optimally adjusted to the AL-KO chassis.



The HYMER T-Class CL

Simply spacious.

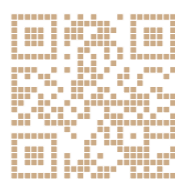

The HYMER T-Class CL sets new standards in its class. The 2.12 metres headroom alone exceeds the usual standard by far. As a result, the interior design concepts are exceptionally generous – despite a laden weight of less than 3.5 tons. No other semi-integrated model comes as close to the high comfort standard found in integrated motorhomes. The overhead storage cupboards and living room floor extend right to the front, as in a Liner. The upholstered B-pillar blends seamlessly into the generous seating

area, which also incorporates the swivel-style driver and passenger seats. The HYMER T-Class CL can be supplied with or without a fold-down bed. Underneath the beds in nearly all models is a huge garage with an internal loading height of 1.14 metres – the kind of dimensions you'd normally expect to find in an integrated vehicle. Scooters, bikes, bulky luggage – you name it: this garage will take up to 450 kilos. And it still leaves you plenty of headroom above the rear beds.

Profile *

Weight: 3,500 – 4,500 kg

Length: 6.69 m – 7.49 m

Width: 2.35 m

Height: 2.90 m

Berths: 2 – 5

HYMER T-Class CL highlights

Optimal standard features.

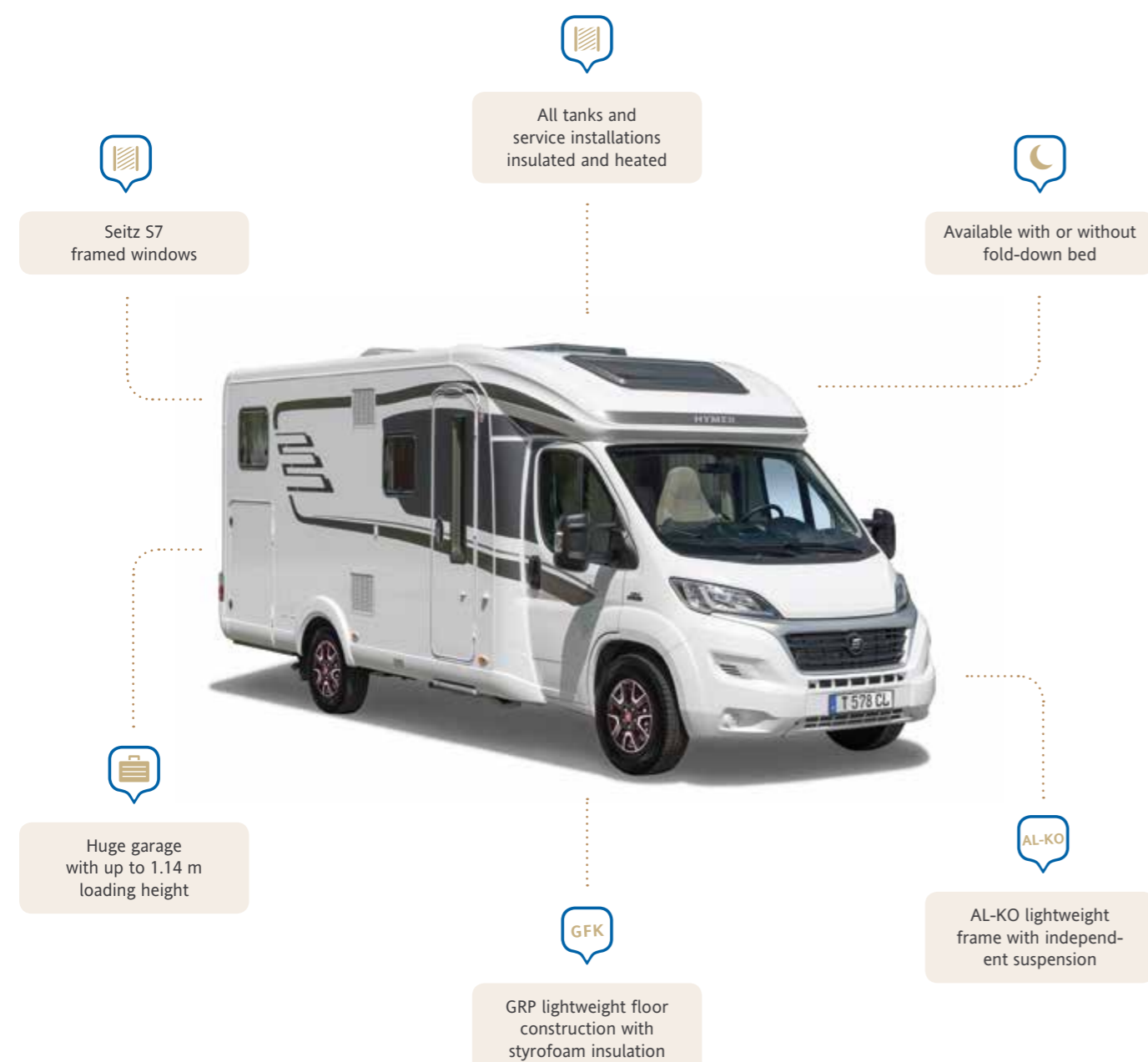

* Maximum values. Further technical data can be found in the layout overview on page 56/57.

The generous interior of the HYMER T-Class CL is matched by its level of equipment. A range of high-end features are included as standard, from the vehicle body through to the high-quality details of the interior furnishings. Visit your HYMER dealer and see the difference for yourself.

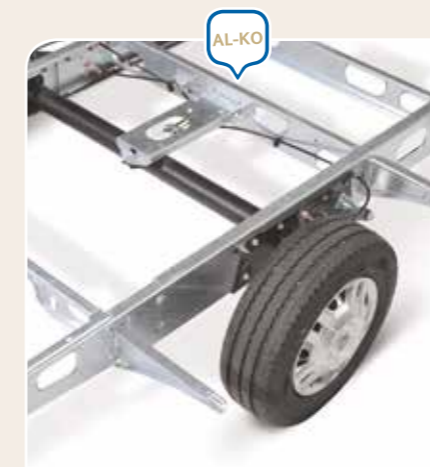

Tailor-made undercarriage

The specially developed AL-KO lightweight grey frame with independent suspension forms the perfect basis for the motorhome body. Its optimally positioned wheelbase ensures equal weight distribution, even when the vehicle is fully loaded.

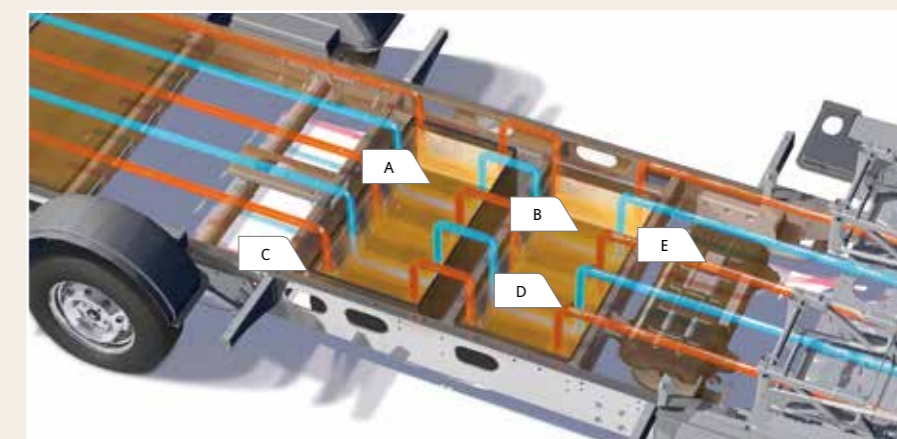

Heated undercarriage

The floor conceals the fresh water (A) and grey water tank (B) in insulated trays (C), which have hot air flowing through them (D). All the plumbing and wiring (E) is accommodated in

the heated living space, safe from frost. The numerous, optimally distributed hot air outlets guarantee perfect climate control throughout the whole vehicle.



Large garage doors

The capacious and – thanks to large doors – easily accessible garage accommodates a payload of up to 450 kilos. What's more, there's still plenty of space above for the rear beds so you needn't worry about bumping your head.



Truma Combi 6 heater

Installed as standard, the 6,000W Truma Combi 6 heater easily maintains a cosy temperature throughout the interior even when it's freezing outside. Its central location under the seating area means that the heat is distributed optimally throughout the vehicle.

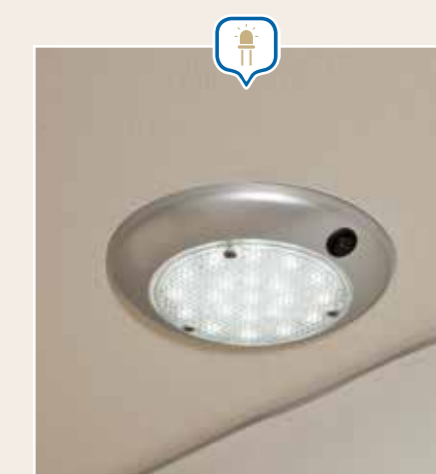

Energy-saving LEDs

The interior lighting throughout the vehicle features LED technology as standard. This cuts energy consumption by 3/4 and gives you hours of extra battery life. Since LEDs don't get hot, this also improves fire and accident safety.

The HYMER T-Class CL impresses with an extensive range of standard features seldom found in semi-integrated motorhomes. Practical home comforts make it a joy to spend time in your motorhome and ensure a high degree of independence and driving pleasure.

Further standard highlights:
www.hymer.com/t-cl/standard

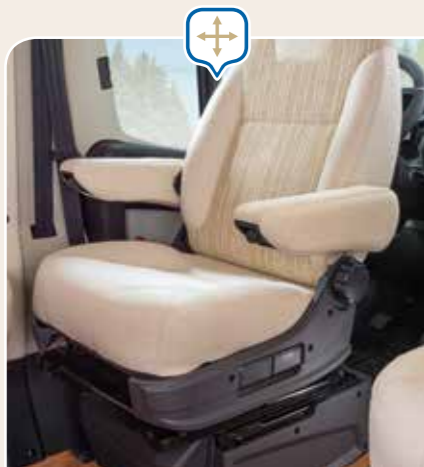
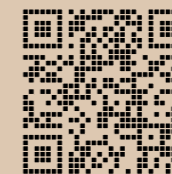

Handy multi-taskers

The swivelling and height-adjustable lounge seats in the cab are fully upholstered in the same fabric as the living area. Their exceptional seating comfort and large, tiltable arm rests are ideal for settling down to watch TV and for relaxed driving.



Smooth transition

The floor echoes the smooth transition between the cab and the body of the vehicle. The floor area between the driver and front passenger seat has a reinforced, non-slip bridge allowing easy access to the cab.

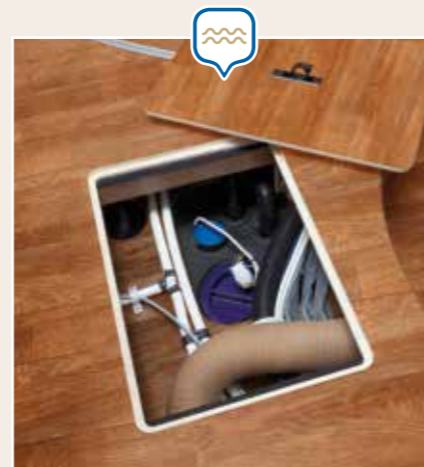

Greater independence

The large water tanks mean you can go further before you have to fill up again, giving you more freedom and spontaneity. The fresh water tank holds 155 litres and the grey water tank 100 litres.

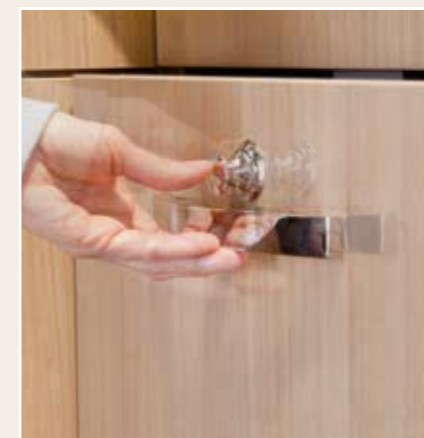

Safe handling

All kitchen drawers are equipped with ball bearings for an ultra-smooth action. They feature high-quality Servo-Soft closing and one-hand push-locks which prevent the drawers from opening and rattling while the vehicle is in motion.



Large, flexible table top

At the centre of the seating area is a sturdy table with a large top. A pull-out extension allows convenient access from the front passenger seat and the opposite bench seat too when required.



Washing and chopping

No space is wasted in the well-designed kitchen. The fitted sink cover converts the sink at a stroke into a handy chopping board for your freshly washed vegetables.



Wired for radio and TV

Loudspeakers in the sleeping and living area, wiring and sockets and a radio aerial are factory-fitted in every vehicle. All you need to do is plug in and play!

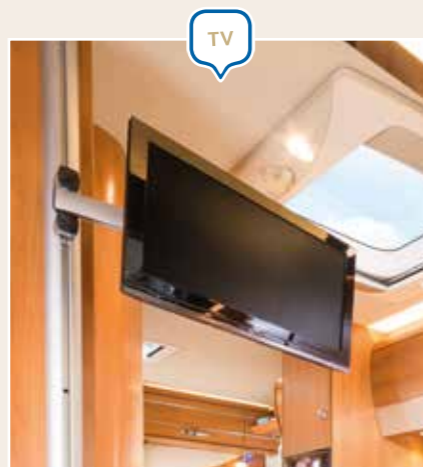

Flat screen bracket

The flexible bracket (position depending on layout) allows you to adjust the exclusive flat screen TV (optional) quickly and easily to the optimal angle for relaxed viewing.

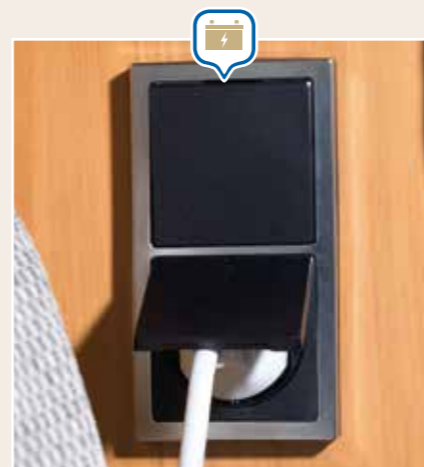

Plenty of sockets

Four 230V and two 12V sockets provide plenty of power for your appliances. The seating area, bathroom and kitchen have points for 230V appliances, while 12V appliances can be plugged in at the TV point and dashboard.



At a glance

The easy-to-read control panel allows you to check the fresh water and grey water levels, the battery voltage, the load at the 230V sockets and other useful data. That way you can keep an eye on your resources at all times.



Space for kitchen appliances

The integrated pull-out section (depending on layout) in the overhead storage cupboard above the kitchen allows instant access to a coffee machine, toaster, kettle or other kitchen appliance. The storage compartment also comes with a 230V socket.

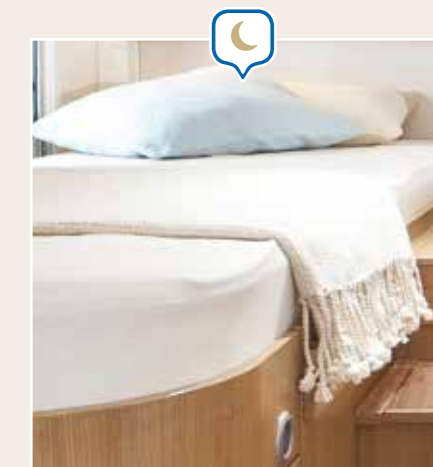

Superior sleeping comfort

All beds are equipped with high-quality multi-zone cold foam mattresses that provide the right support for all areas of the body. The premium slatted frame in the rear guarantees good ventilation.

Illustrations for example purposes only.



Living comfort

Designed for well-being.

1 Bright and cosy

The interior of the T 588 CL is equipped as standard with a warm Trentino pear wood furniture finish and Castello fabric design.

2 Light and airy

The living area of the T 668 CL makes a light and airy impression thanks to the optional large rooflight and impressive panoramic roof with acrylic glass frame and integrated LED lighting in the cab.

3 Comfy seating

The T 678 CL boasts an optionally available L-shaped seating area in the new fabric combination Millau. Access to the seating is improved enormously by the 360-degree rotating table.

4 Excellent storage

The small storage compartment in the side seat by the entrance to the T 588 CL is a highly practical feature, ideal for tidying away shoes and other items.

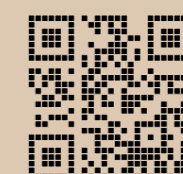
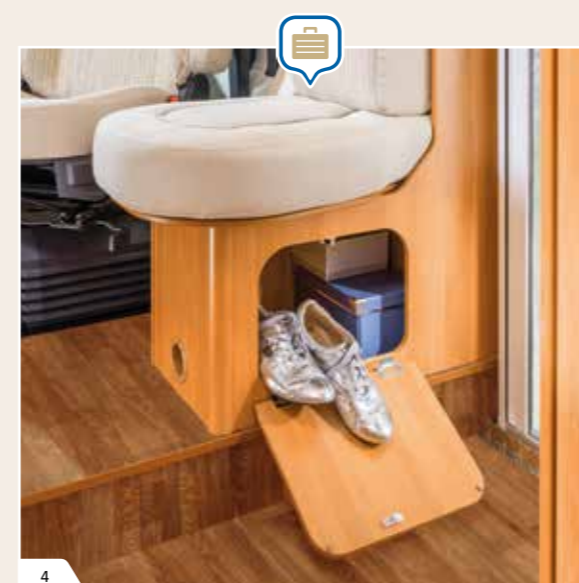

Step aboard the T-CL
with a virtual tour:

www.hymer.com/t-cl/360



Sleeping comfort

An oasis of peace for sleepyheads.

1 Aesthetic and practical

The built-in extending ladder can be used to support an extra cushion between the single beds in the rear of the T 678 CL – seen here in the furniture finish Umbria Select.

2 Stylish bed

The large transverse double bed with multi-zone cold foam mattress in the T 614 CL couldn't be more inviting.

3 Room for the grandchildren

The optionally available fold-down bed, as seen here in the T 614 CL, offers a generous sleeping surface and is integrated into the living area – so you can take the grandchildren too!

4 Extra berth

In this optional version the table can be lowered and an additional cushion inserted to make an extra berth.

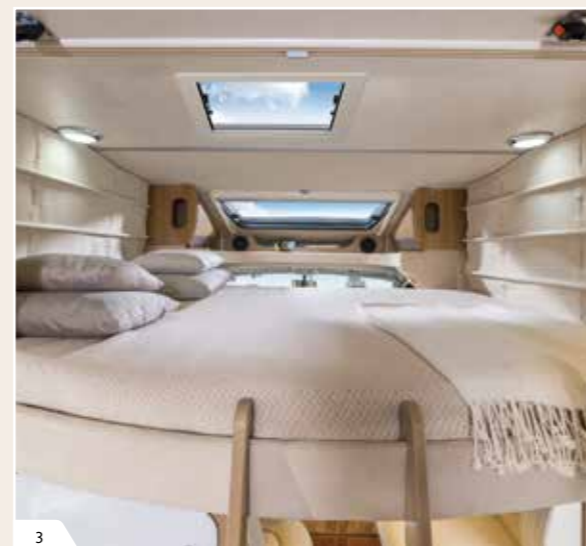

Kitchen comfort



Everything you need to prepare the perfect meal.



1 Spacious kitchenette

Wide kitchenette in the T 614 CL with large, deep work surface and side refrigerator – also with enclosed storage compartment on request.

2 Ample storage space

Kitchen in the T 678 CL with wide-opening drawers and large refrigerator opposite.

3 More space for kitchen appliances

The pull-down storage compartment over the kitchen sink in the T 614 CL is not only highly practical but also ideal for housing additional kitchen appliances.

Bathroom comfort

The generous bathroom area leaves nothing to be desired.

1 Clear organisation

The bathroom in the T 678 CL is clearly structured with a separate shower, a separate bathroom and toilet area and an intermediate dressing room.



2 Clean and dry

The comfort bathroom in the T 588 CL has a shower cubicle which can be closed off to ensure a clean, dry space in front of the washbasin.

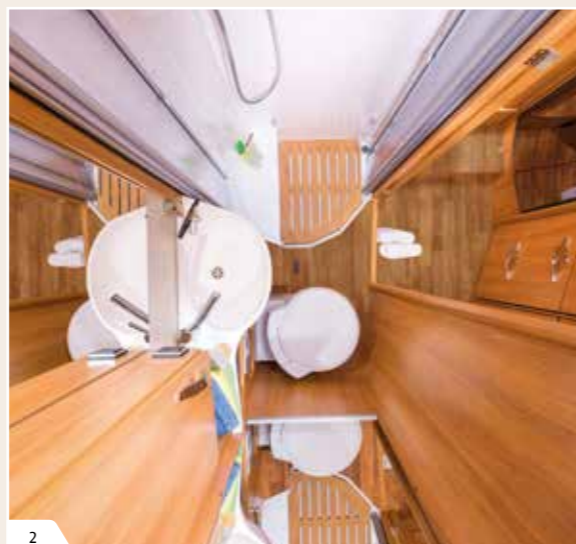

3 Luxury for your clothes

The rear bathroom of the T 668 CL impresses with its spacious separate shower and floor-to-ceiling wardrobe.

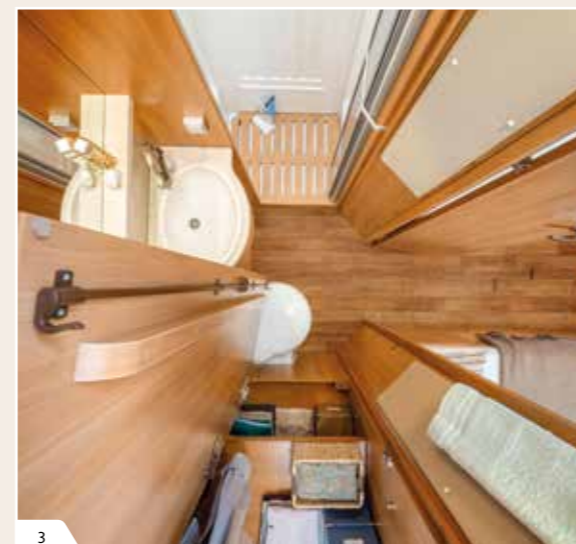

4 Ample shelving

Sink area in the bathroom of the T 698 CL with cabinet in Umbria Select finish and plenty of shelf space.



Extra comfort to order

Want to add a more personal touch of class to your HYMER motorhome? There is a wealth of attractive extras available to customise your van. Below are just a few of them – your HYMER dealer will be happy to provide details of the full range.



1



2

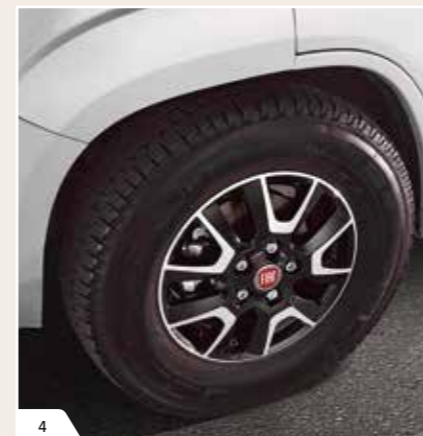

4



3

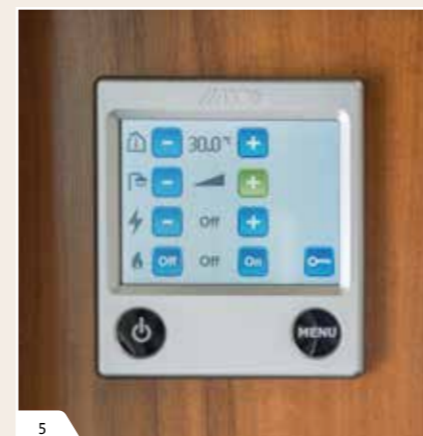

5



6

1 Light and shade

The large, pop-up panoramic roof above the cab seats brings extra light into the living area. Privacy and sun protection is provided by the integrated blackout blind.

2 Restful sleep

The HYMER comfort sleeping system with high-quality cup slatted bed frames maximises the benefits of the multi-zone cold foam mattresses. Each area of the body is supported with the ideal counter-pressure for snug and restful sleep.

3 Tasteful lighting

The ambient lighting ensures a tasteful, cosy atmosphere throughout the living area thanks to indirect LED fittings with high-quality acrylic glass frames.

4 Distinctive lightness

The high-quality aluminium rims lend the vehicle extra individuality and class on the outside too. Their low weight not only increases the payload reserves but also improves the effectiveness of the suspension for an easier drive.

5 Hot-water heating

As a high-quality alternative to hot air heating, the ALDE hot water heating system with its numerous convectors provides a particularly pleasant warmth. The system is also available with an energy-saving heat exchanger on request.

6 High-tech in the kitchen

The full-height TEC Tower is the ultimate in modern motorhome kitchen technology. It comprises a fridge freezer (160 litres), oven and grill in a timeless elegant design and impresses both in terms of looks and versatility.

Illustrations for example purposes only.



Layouts and technical data

THE HYMER T-Class CL models at a glance.

Technical data

Chassis



Overall length (cm)	669	699	699	720
Overall width (235 cm)	✓	✓	✓	✓
Overall height (290 cm)	✓	✓	✓	✓
Headroom in living area (212 cm)	✓	✓	✓	✓
Mass in running order approx. (kg)	2,820	2,980	2,900	2,930
Payload approx. (kg) / O	680 / 1,030	520 / 870	600 / 950	570 / 920
Max. permissible laden mass (kg) / O	3,500 / 3,850	3,500 / 3,850	3,500 / 3,850	3,500 / 3,850
Berths + O	♣♣ + ♣	♣♣ + ♣♣♣	♣♣ + ♣	♣♣ + ♣

Overall length (cm)	699	720	749	749	749
Overall width (235 cm)	✓	✓	✓	✓	✓
Overall height (290 cm)	✓	✓	✓	✓	✓
Headroom in living area (212 cm)	✓	✓	✓	✓	✓
Mass in running order approx. (kg)	2,870	2,980	2,990	3,030	3,030
Payload approx. (kg) / O	630 / 980	520 / 870	510 / 860	470 / 820	470 / 820
Max. permissible laden mass (kg) / O	3,500 / 3,850	3,500 / 3,850	3,500 / 3,850	3,500 / 3,850	3,500 / 3,850
Berths + O	♣♣ + ♣♣♣	♣♣ + ♣♣♣	♣♣ + ♣♣♣	♣♣ + ♣♣♣	♣♣ + ♣♣♣

All technical data can be found in the current motorhome price list.

O = Optional extras



The HYMER T-Class SL

The top of the semi-integrated range.

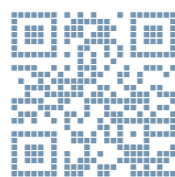

The new semi-integrated HYMER T-Class SL boasts a standard of comfort approaching that of a fully integrated motorhome – and all with an unladen weight of well below 3.5 tons. Featuring new layout concepts, it builds on the CL sister model but with the addition of a double floor containing the plumbing/wiring and cellar compartments plus a single-level living area floor. Highlights of the new HYMER T-Class SL are its abundant headroom and freedom to move, not to mention its first-class inventory.

This includes comfy furniture in stylish design, a high-quality kitchen outfit featuring the new-generation Smart-Tower refrigerator plus countertop lighting, superior sleeping and bathroom comfort, high-volume fresh and grey water tanks, large left and right garage doors and a crank-handle rooflight in the lounge – all of which comes as standard. What better travelling companion could you wish for?

Profile *
Weight: 3,500 – 4,500 kg
Length: 6.99 – 7.79 m
Width: 2.35 m
Height: 2.90 m
Berths: 2 – 3

HYMER T-Class SL highlights

All-round excellence from bodywork to inventory.

Large garage doors left and right

New kitchen with solid surface worktop.

Single-level living area floor

Large fresh water- (160 l) and grey water tank volume (140 l)

Multi-purpose double floor with cellar compartments

AL-KO lightweight frame with independent suspension

Sophisticated standard features and a high level of comfort are the hallmarks of the HYMER T-Class SL. And that goes for bodywork and interior alike. Want to find out more? Simply visit your HYMER dealer.

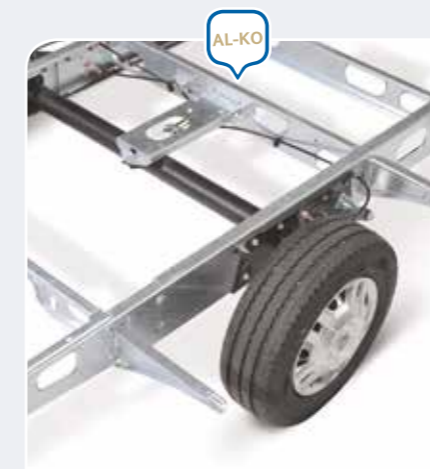

Tailor-made undercarriage

The specially developed AL-KO lightweight frame with independent suspension forms the perfect basis for the motorhome body. Its optimally positioned wheelbase ensures equal weight distribution, even when the vehicle is fully loaded.

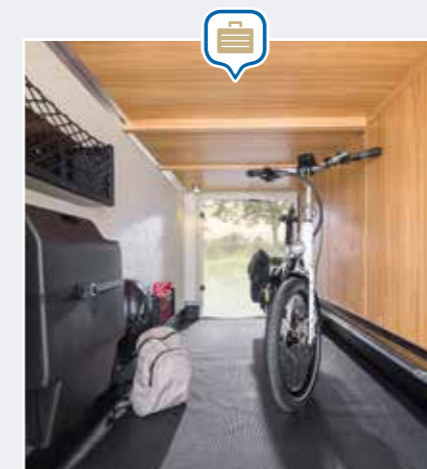

Large garage doors

The capacious and – thanks to large doors – easily accessible garage accommodates a payload of up to 350 kilos. What's more, there's still plenty of space above for the rear beds so you needn't worry about bumping your head.



Lasting protection from below

The indestructible GRP underbody makes the vehicles practically immune to weather damage. Stone damage, grit and dirt are likewise kept at bay – a solid foundation for the entire service life of your motorhome.



Truma Combi 6 heater

Installed as standard, the 6,000W Truma Combi 6 heater easily maintains a cosy temperature throughout the interior even when it's freezing outside. Its central location under the seating area means that the heat is distributed optimally throughout the vehicle.



Brightness by day and night

The large crank-handle rooflight in the living area lets in plenty of direct daylight to create a pleasant, natural ambience in the interior of the vehicle. At night, uniform lighting is provided by the integrated LED spotlights.

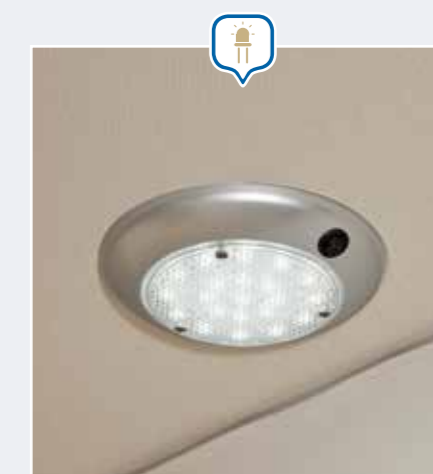

Energy-saving LEDs

The interior lighting throughout the vehicle features LED technology as standard. This cuts energy consumption by 3/4 and gives you hours of extra battery life. Since LEDs don't get hot, this also improves fire and accident safety.

* Maximum values. Further technical data can be found in the layout overview on page 74/75.

The HYMER T-Class SL has all the key ingredients for carefree and independent motor-homing. That includes a pleasant living environment and a wealth of important details that make all the difference to your holiday.

Further standard highlights:
www.hymer.com/t-sl/standard

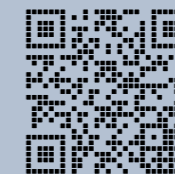

Level living area

All layouts have a level floor throughout the living area, unimpeded by raised sections. That way none of the headroom is lost and there are no obstacles to trip over, especially in the dark.

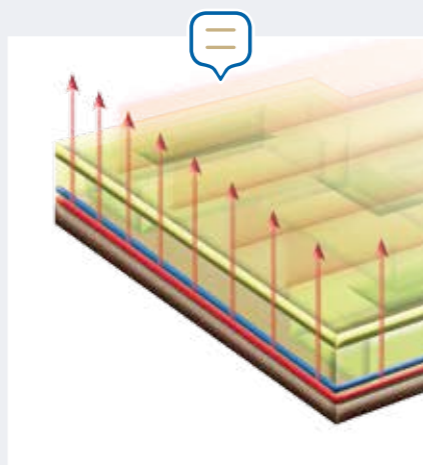

Multi-purpose double floor

Underfloor heating, a frost-protected service cavity and an additional heated storage compartment are all-inclusive thanks to the proven, 12.5 cm thick multi-purpose double floor with hot-air nozzles between the upper floor surface (3 cm) and underfloor (3.5 cm).

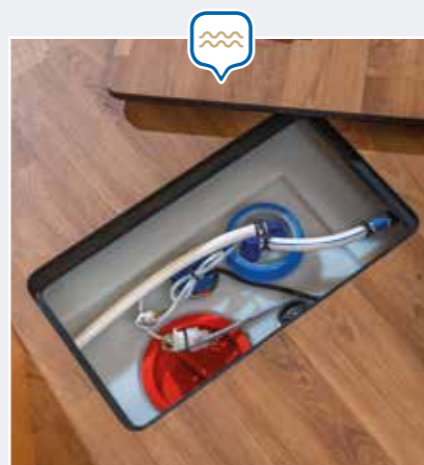

Greater independence

The large water tanks mean you can go further before you have to fill up again, giving you more freedom and spontaneity. The fresh water tank in the double floor holds 160 litres, the grey water tank 140 litres.

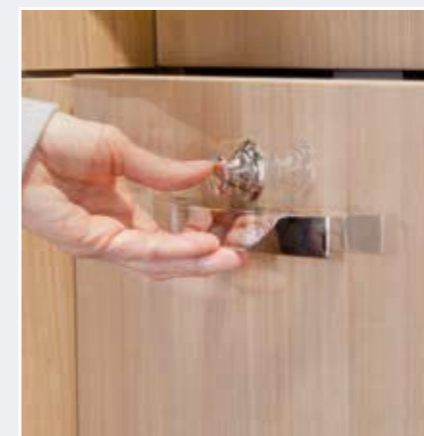

Safe handling

All kitchen drawers are equipped with ball bearings for an ultra-smooth action. They feature high-quality Servo-Soft closing and one-hand push-locks which prevent the drawers from opening and rattling while the vehicle is in motion.

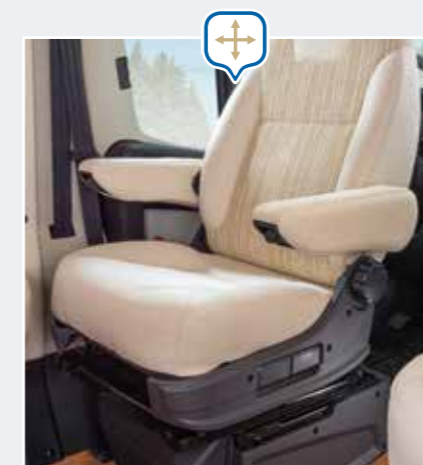

Handy multi-taskers

The swivelling and height-adjustable lounge seats in the cab are fully upholstered in the same fabric as the living area. Their exceptional seating comfort and large, tiltable arm rests are ideal for settling down to watch TV and for relaxed driving.

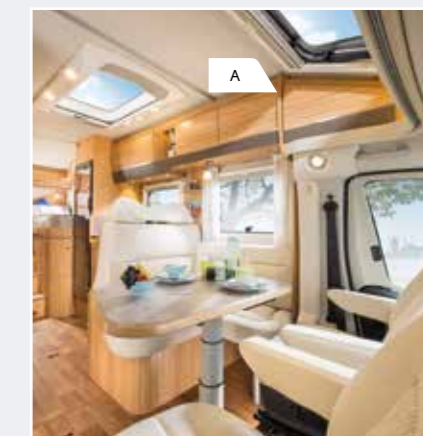

Harmonious interior

The continuous overhead storage cupboards (A) above the seating area connect the cab to the body both visually and functionally. This feature – along with the revolving cab seats – turns the living area into a harmonious unit, as in an integrated vehicle.



Wired for radio and TV

Loudspeakers in the sleeping and living area, wiring and sockets and a radio aerial are factory-fitted in every vehicle. All you need to do is plug in and play!



Plenty of sockets

Five 230V and three 12V sockets provide plenty of power for your appliances. The seating area, bathroom and kitchen have points for 230V appliances, while 12V appliances can be plugged in at the TV point and dashboard.

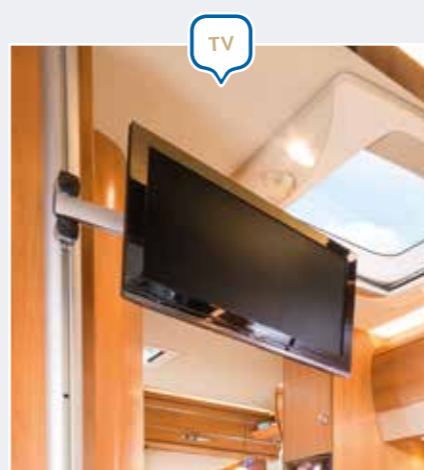

Flat screen bracket

The flexible bracket (position depending on layout) allows you to adjust the exclusive LED flat screen TV (optional) quickly and easily to the optimal angle for relaxed viewing.



Space for kitchen aids

The integrated pull-out section (depending on layout) in the overhead storage cupboard above the kitchen allows instant access to a coffee machine, toaster, kettle or other kitchen appliance. The storage compartment also comes with a 230V socket.



Smart-Tower refrigerator

Despite its slim design, the standard Smart-Tower refrigerator boasts a capacity of 142 litres plus a 15-litre freezer compartment. Its interior is also clearly organised with practicality in mind.

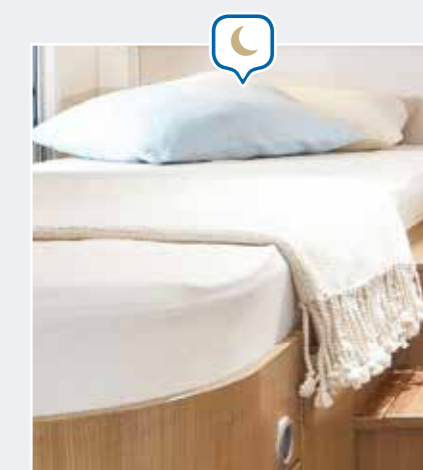

Superior sleeping comfort

All beds are equipped with high-quality multi-zone cold foam mattresses that provide the right support for all areas of the body. The breathable mattress toppers in the rear ensure good ventilation.

Illustrations for example purposes only.



Living comfort

Live like you do in your own four walls – only on wheels!

1 Bright and cosy

The optional L-shaped seating area with revolving table in the T 568 SL radiates an atmosphere of cosiness with its Legno Lombardo furniture finish and bright Castello fabric design.

2 Plenty of space at the table

The standard semi-dinette in the T 588 SL is upholstered in the new fabric combination Millau. It also features a table with a 360-degree swivel extension.

3 Stylish leather design

The living area of the T 588 SL has a bright decor sporting the new imitation leather fabric combination Cremissimo. The crank-handle rooflight comes as standard.

4 No trip hazards

The living area is level throughout, from the cab to the rear. At the same time, the headroom in the interior is immense, allowing ample freedom of movement.

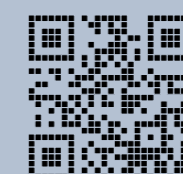
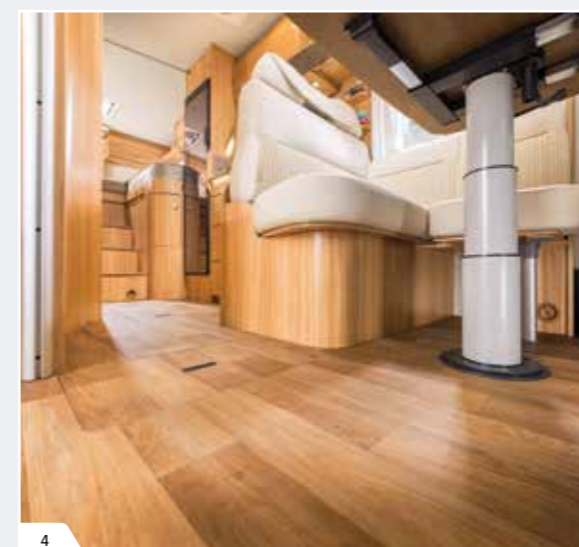

Step aboard the T-SL with a virtual tour:

www.hymer.com/t-sl/360



Sleeping comfort

Perfect sleeping quarters for weary travellers.

1 Cosy and welcoming

The comfy single beds in the rear of the T 568 SL always look fresh and inviting with their Legno Lombardo furniture finish.

2 Extra berth

In the T 568 SL and T 588 SL, the driver's seat can be converted into an extra berth (optional) using the additional cushion.

3 Organisation for your wardrobe

The substantial stowage space under the single beds (except in the T 668 SL) is perfect for tidying away various items of clothing.

4 Elegant rear section

The rear section of the T 668 SL with its twin beds and Trentino pear wood furniture finish is a model of elegance – and the separate rear bathroom is the crowning glory.

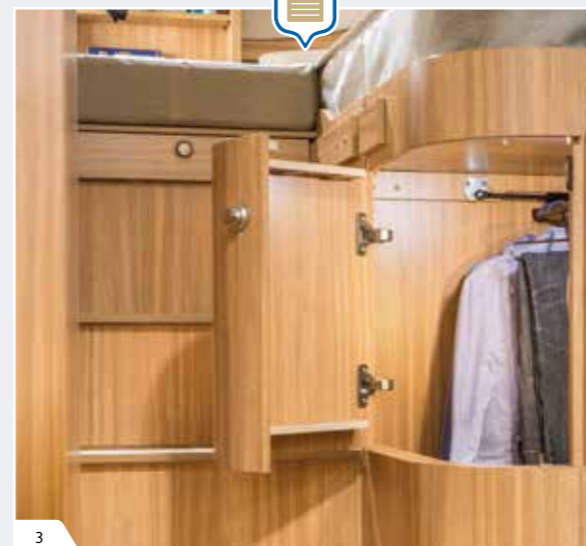

Kitchen comfort



1

The dream of every mobile hobby cook.



2

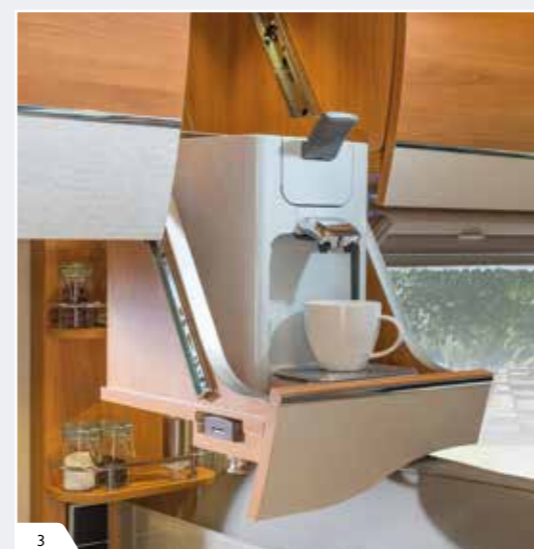

3

1 Optimally equipped

The kitchen in the T 568 SL boasts a Smart-Tower refrigerator (142 litres) as standard and offers plenty of storage space for cooking utensils and groceries.

2 A pleasant place to potter

Pottering in the kitchen is a real pleasure with the solid surface worktop (optional) and standard countertop lighting.

3 Mixers, toasters & co.

The pull-out compartment for kitchen appliances is easily lowered by hand and comes complete with 230V socket. It makes an ideal home for your mixer, toaster or coffee machine.

Bathroom comfort



Stylish and storage-friendly.

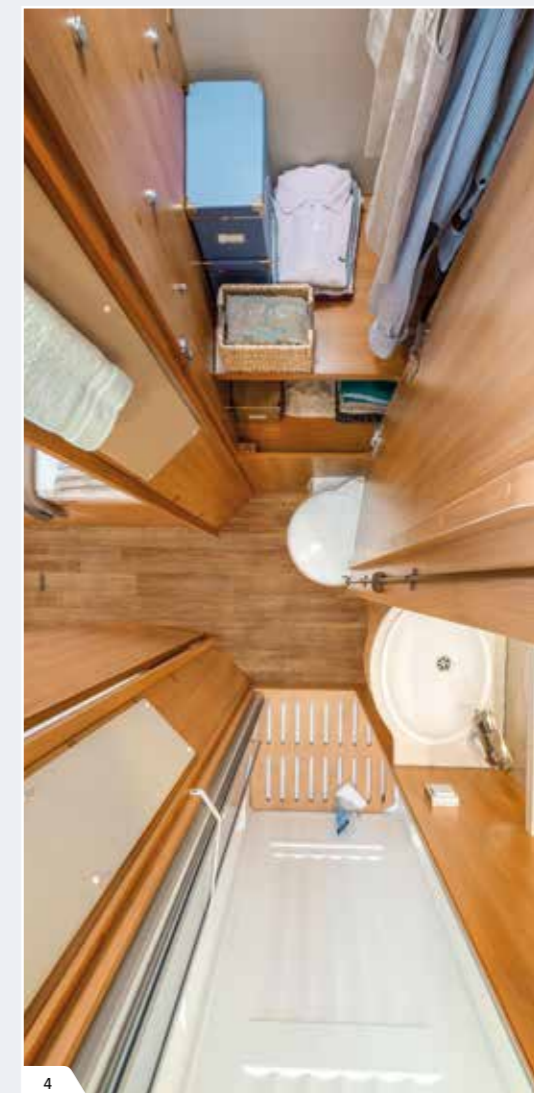
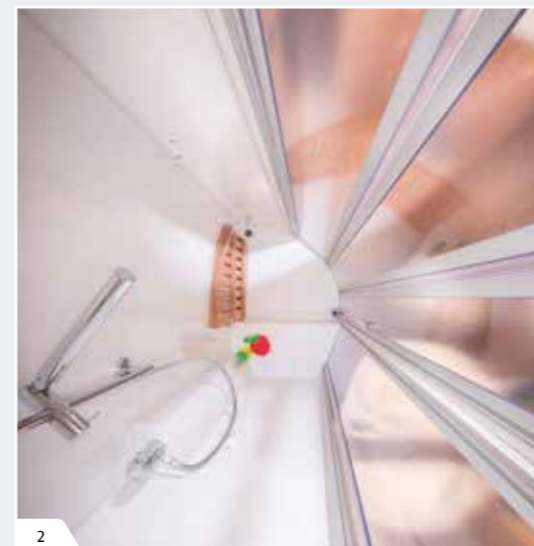

1 Plenty of space for personal care

The roomy comfort bathroom has a separate shower cubicle with fixed walls and a large standing area in front of the washbasin.

3 Authentic porcelain look

The high-quality washbasin consists of Cool Glass – pressed glass powder that looks and feels like porcelain.

2 Ample freedom of movement

The shower in the comfort bathroom of the T 568 SL has a generously dimensioned tray allowing plenty of room to manoeuvre.

4 Optimal organisation

Generous rear bathroom of T 668 SL with huge ceiling-high wardrobe and spacious separate shower.

Extra comfort to order

Want to add a more personal touch of class to your HYMER motorhome? There is a wealth of attractive extras available to customise your van. Below are just a few of them – your HYMER dealer will be happy to provide details of the full range.



1 Light and shade

The large, pop-up panoramic roof above the cab seats brings extra light into the living area. Privacy and sun protection is provided by the integrated blackout blind.

2 Restful sleep

The HYMER comfort sleeping system with high-quality cup slatted bed frames maximises the benefits of the multi-zone cold foam mattresses. Each area of the body is supported with the ideal counter-pressure for snug and restful sleep.

3 Tasteful lighting

The ambient lighting ensures a tasteful, cosy atmosphere throughout the living area thanks to indirect LED fittings with high-quality acrylic glass frames.

4 High-tech in the kitchen

Home-from-home kitchen comforts: the Thetford Aspire hob and oven combination caters to almost every culinary requirement, including a grill for heating things up quickly.

5 Hot-water heating

As a high-quality alternative to hot air heating, the ALDE hot water heating system with its numerous convectors provides a particularly pleasant warmth. The system is also available with an energy-saving heat exchanger on request.

6 Distinctive lightness

The high-quality aluminium rims lend the vehicle extra individuality and class on the outside too. Their low weight not only increases the payload reserves but also improves the effectiveness of the suspension for an easier drive.

Illustrations for example purposes only.



Layouts and technical data

The HYMER T-Class SL models at a glance.

Technical data

Chassis



	T-Class SL 568	T-Class SL 588	T-Class SL 668
Overall length (cm)	699	729	749
Overall width (235 cm)	✓	✓	✓
Overall height (290 cm)	✓	✓	✓
Headroom in living area (198 cm)	✓	✓	✓
Mass in running order approx. (kg)	2,940	2,995	*
Payload approx. (kg) / O	560 / 910	505 / 855	* / *
Max. permissible laden mass (kg) / O	3,500 / 3,850	3,500 / 3,850	3,500 / 3,850
Berths + O	♣♣+♣	♣♣+♣	♣♣+♣

	T-Class SL 704
Overall length (cm)	779
Overall width (235 cm)	✓
Overall height (290 cm)	✓
Headroom in living area (198 cm)	✓
Mass in running order approx. (kg)	*
Payload approx. (kg) / O	* / *
Max. permissible laden mass (kg) / O	4,500
Berths + O	♣♣+♣

All technical data can be found in the current motorhome price list.

O = Optional extras
* Data not yet confirmed on going to press.

Standard chassis:
Fiat AL-KO Ducato



In HYMER motorhomes the overall length and width, unladen and laden mass are optimally adjusted to the AL-KO chassis.



Standard chassis:
Mercedes Sprinter



Semi-integrated Mercedes-based
Hymer motorhome weighing
less than three tons

The HYMER ML-T

Premium semi-integrated model on Mercedes base.

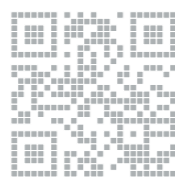

The new HYMER ML-T unites state-of-the-art drive technology and innovative lightweight construction with optimal comfort in an agile semi-integrated vehicle. It is the result of a collaboration between two brands in which quality plays an important, if not the most important role. Every corner of the new HYMER semi-integrated speaks of comfort and convenience: the single-level living area floor, the large seating area and the stand-

ard extending table are just a few examples. Despite weighing less than 3.5 tons, this new semi-integrated sprinter gives you complete comfort coupled with excellent manoeuvrability in traffic. The HYMER ML-T also comes with a comprehensive safety package. What's more, it boasts a range of standard features and additional comfort which are unrivalled in this class.

Profile *
Weight: 3,500 – 4,200 kg
Length: 6.98 m
Width: 2.22 m
Height: 2.90 m
Berths: 2 – 3

HYMER ML-T highlights

A perfect combination.

Huge garage with up to 1.21 m loading height

All tanks and service installations insulated and heated

Light, slender and manoeuvrable thanks to an outside width of 2.22 m

Single-level living area floor

Sports-style safety chassis

GRP lightweight floor construction with styrofoam insulation

GFK

The spaciousness of the HYMER ML-T is matched by its level of equipment. A range of high-end features are included as standard, from the vehicle body through to the high-quality details of the interior furnishings. Visit your HYMER dealer and see the difference for yourself.



Powerful rear-wheel drive

The rear-wheel drive of the HYMER ML-T has an impressive two-ton towing capacity. That means you can rely on smooth, superior handling in all traffic situations – and an extremely comfortable drive into the bargain.



Stable roadholding

The sports-style safety chassis guarantees tight, stable roadholding even in extreme situations, thereby reducing any rolling motion and ensuring a comfortable drive.

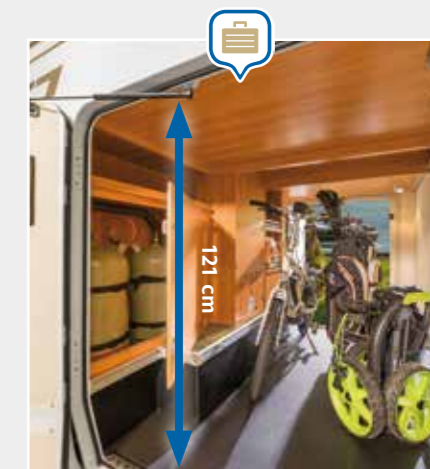

High-capacity garage

Two standard garage doors on the left and right with a loading gauge of 121 cm, 350 kilos of loading capacity and high-quality gas pressure shock absorbers give you ample scope for stowage.

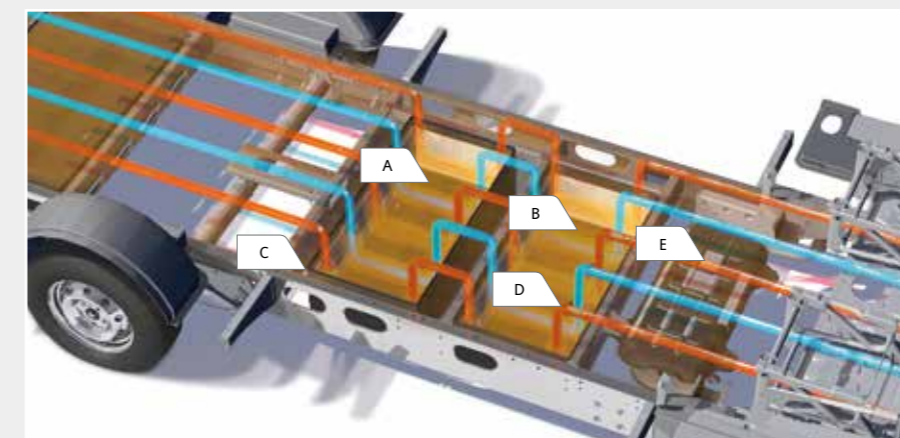

Heated undercarriage

The floor conceals the fresh water (A) and grey water tank (B) in insulated trays (C), which have hot air flowing through them (D). All the plumbing and wiring (E) is accommodated in

the heated living space, safe from frost. The numerous, optimally distributed hot air outlets guarantee perfect climate control throughout the whole vehicle.



Lasting protection from below

The indestructible GRP underbody makes the vehicles practically immune to weather damage. Stone damage, grit and dirt are likewise kept at bay – a solid foundation for the entire service life of your motorhome.

* Maximum values. Further technical data can be found in the layout overview on page 92/93.

From lighting and heating to seating comfort, the vehicle inventory will amaze you with its remarkable variety of practical components. Travelling has never been so free and easy!

Further standard highlights:
www.hymer.com/ml-t/standard

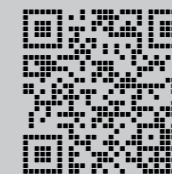

Truma Combi 6 heater

Installed as standard, the 6,000W Truma Combi 6 heater easily maintains a cosy temperature throughout the interior even when it's freezing outside. Its central location under the seating area means that the heat is distributed optimally throughout the vehicle.

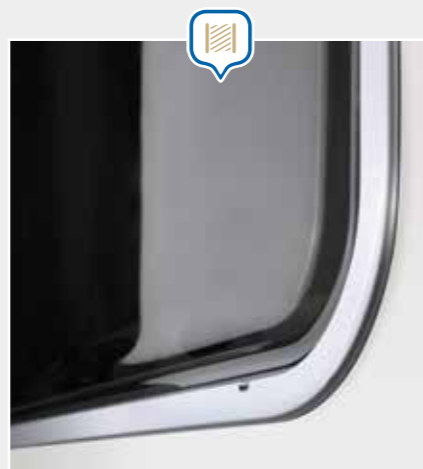

Great view, no thermal bridges

The high-quality Seitz-S7 framed windows are fitted with acrylic double glazing for optimal thermal insulation. The powder-coated aluminium frame is particularly lightweight and sturdy and is likewise equipped with an insulating layer to protect against thermal bridging.

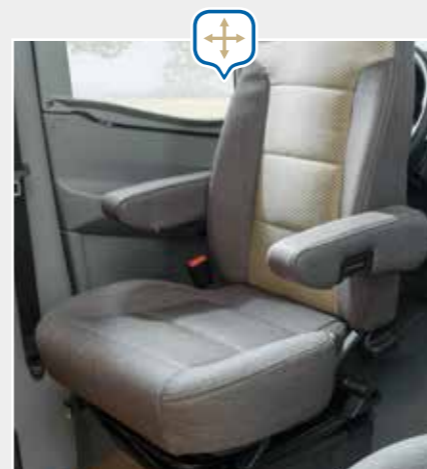

Handy multi-taskers

The swivelling and height-adjustable lounge seats in the cab are fully upholstered in the same fabric as the living area. Their exceptional seating comfort and large, tiltable arm rests are ideal for settling down to watch TV and for relaxed driving.

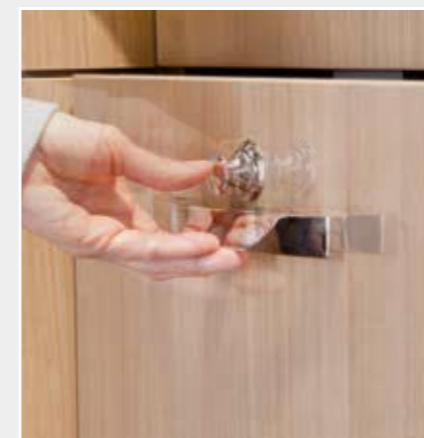

Safe handling

All kitchen drawers are equipped with ball bearings for an ultra-smooth action. They feature high-quality Servo-Soft closing and one-hand push-locks which prevent the drawers from opening and rattling while the vehicle is in motion.

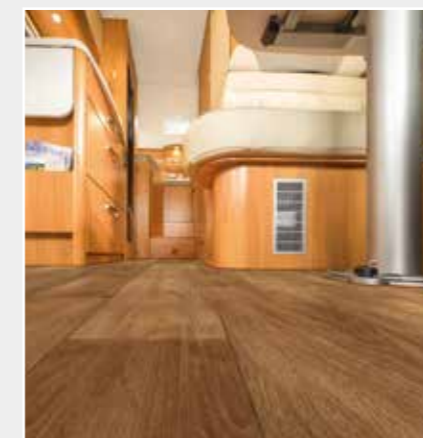

Level living area

The interior of the HYMER ML-T has a level floor from the cab right through to the rear – an inestimable advantage for older motor-home users who no longer need worry about trip hazards.

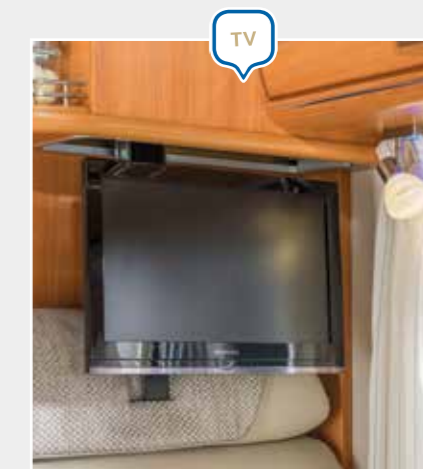

Optimal TV viewing

Often available as an add-on only, the flexible flat screen bracket is included here as standard. That means you can move the LED flat screen to the ideal viewing position so you can watch TV in comfort.



Energy-saving LEDs

The interior lighting throughout the vehicle features LED technology as standard. This cuts energy consumption by 3/4 and gives you hours of extra battery life. Since LEDs don't get hot, this also improves fire and accident safety.



Wired for radio and TV

Loudspeakers in the sleeping and living area, wiring and sockets and a radio aerial are factory-fitted in every vehicle. All you need to do is plug in and play!



Handy exterior light

The high-power LED awning light with rain deflector comes as standard. It lights up a wide area outside the entrance door so you can exit the vehicle safely in the dark.



Smart-Tower refrigerator

Despite its narrow design, the Smart-Tower refrigerator with its clearly organised interior has an impressive capacity of 142 litres, plus a 15-litre freezer compartment, and is fitted as standard.

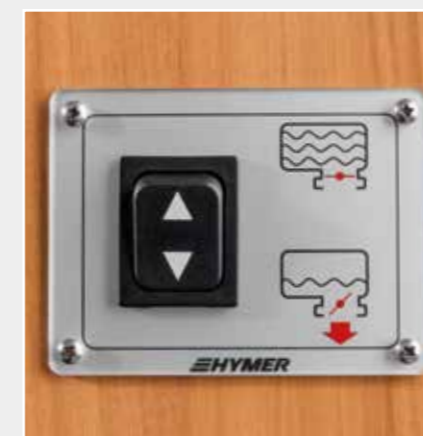

Convenient drainage

The grey water tank can be drained at the touch of a button. It is equipped with an electric valve which can be instantly opened and closed via the switch at the side of the rear garage.

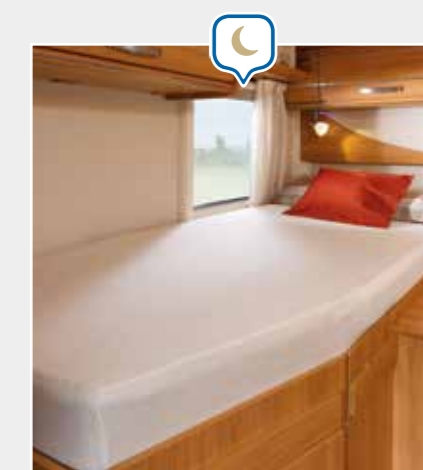

Superior sleeping comfort

All beds are equipped with high-quality multi-zone cold foam mattresses that provide the right support for all areas of the body. Breathable mattress toppers in the rear ensure good ventilation.

Illustrations for example purposes only.



Living comfort

The ultimate in feel-good design.

1 Snug living area

Civilised living in the HYMER ML-T 580 with its stylishly designed seating area in Trentino pear wood furniture finish and the new Cremissimo imitation leather combination.

2 Ample seating

Up to 4 people can be accommodated in the comfort seating area of the HYMER ML-T 560 with its large table and swivel extension.

3 New seating upholstery

The optionally available L-shaped seating area in the HYMER ML-T 560 is guaranteed to please the motorhoming enthusiast with its attractive new Santorin fabric combination.

4 Optimal viewing

The flat screen bracket stows away neatly and extends downwards so you can adjust the TV to the optimal viewing position.

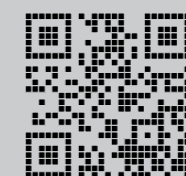
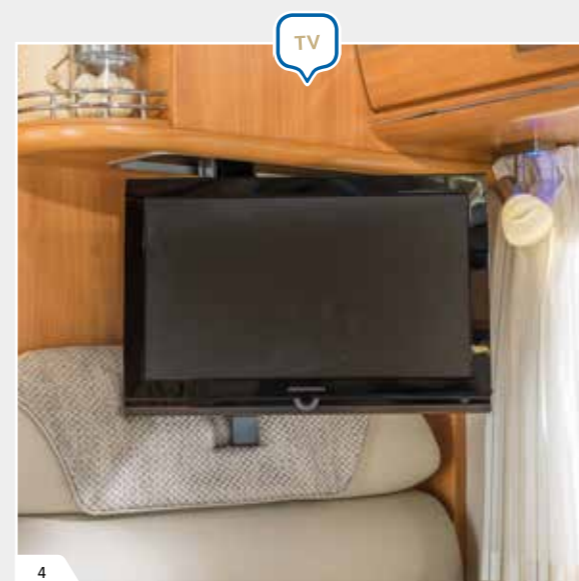

Step aboard the HYMER ML-T with a virtual tour:

www.hymer.com/ml-t/360



Sleeping comfort

Welcome to the world of sweet dreams.

1 High or low

The twin beds in the HYMER ML-T 580 are exceptionally comfortable, and are available in a high or low version as required.

2 Extra-large sleeping area

The twin beds can be readily transformed into an extra-large sleeping area using the optional spare cushion and ladder.

3 Generous dimensions

The double bed in the HYMER ML-T 560 virtually fills the sleeping area with its generously dimensioned surface while remaining easily accessible.

4 Space for your holiday wear

The HYMER ML-T 580 offers plenty of space for clothing thanks to the wardrobe under the twin beds plus the additional tall wardrobe.

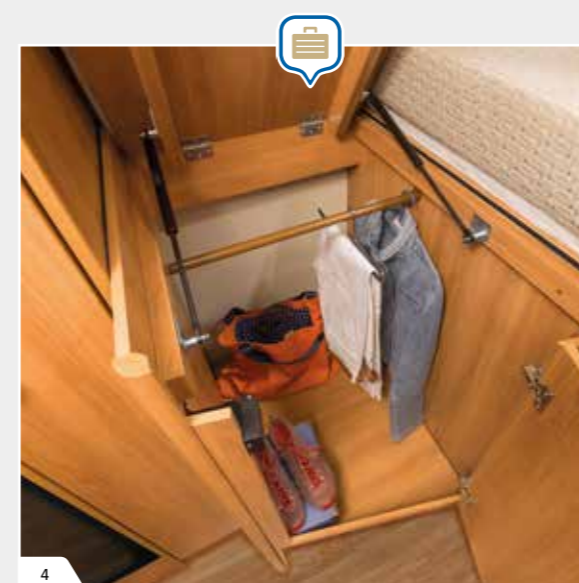

Kitchen comfort



A paradise for ambitious cooks.



1 Large side kitchen

The flexibly partitioned kitchen drawers in various sizes and readily accessible overhead storage cupboards are among the highlights of the large side kitchen.

2 Extendible work surface

The worktop can be extended at a stroke to give you more space to put things, thanks to this clever design.

3 Organisation is everything

The two convenient pull-out drawers in the HYMER ML-T 560 accommodate a variety of kitchen utensils to keep the cooking area neat and tidy.

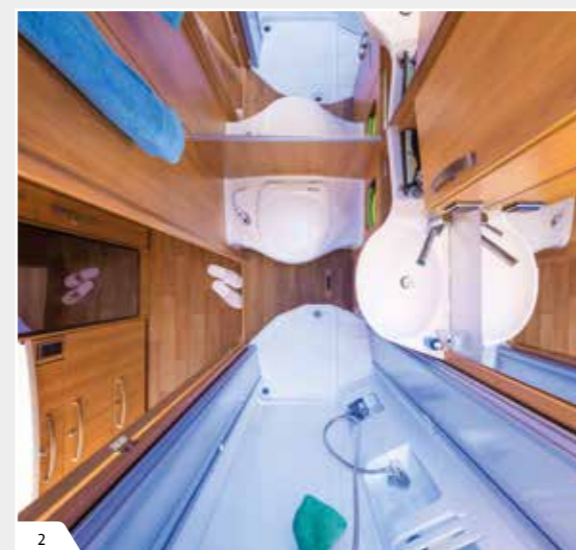

Bathroom comfort

Using the bathroom has never been so much fun!

1 Spacious and modern

The comfort bathroom boasts a separate, spacious shower cubicle with full-size tray, a modern bench toilet and a standing area.

2 No more wet feet!

The separate shower screen has a twofold advantage: you can open it to give you maximum freedom of movement in the bathroom or close it to keep your feet dry outside the shower.

3 Elegant washbasin

The elegant Cool Glass washbasin is an aesthetic highlight, consisting of a premium-grade material made from pressed glass powder.

4 Secure shelves

The generous bathroom cabinet offers bags of storage space. HYMER fits straps to the shelves as standard to keep everything securely in place.

Extra comfort to order

Want to add a more personal touch of class to your HYMER motorhome? There is a wealth of attractive extras available to customise your van. Below are just a few of them – your HYMER dealer will be happy to provide details of the full range.



1



2



4



3

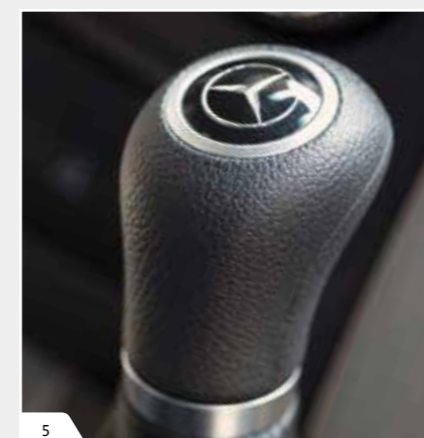

5

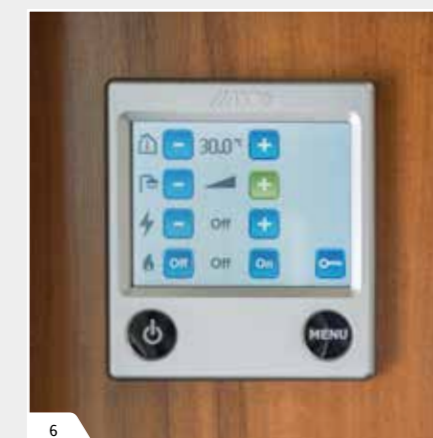

6

1 Driver assistance package

The Collision Prevention Assist emits a signal if you get too close to the vehicle in front, the Lane Assist warns you if you drift off course, and the automatic High Beam Assist ensures optimal night vision.

2 High-tech in the kitchen

The Thetford hob and oven combination offers home-from-home cooking convenience. From baking to grilling to cooking, it caters to every culinary desire – and the individual components are very easy to clean.

3 Power package

Power package with readily accessible second and third battery in the exterior locker door and inverter ensuring a reliable 1,800W power supply for the 230V on-board electrical system.

4 Eye-catching looks

The cab is available in so many colours you'll be spoilt for choice: Grapithe grey metallic, Brilliant silver metallic, Dolomite brown metallic, Obsidian black metallic, Pearl silver metallic (see photo) and many more.

5 Seven-speed transmission

The optionally available 7G-Tronic automatic transmission guarantees a smooth, fuel-optimised drive. The seven forward gears prevent abrupt speed changes when shifting up and down to keep the engine within the ideal rpm range.

6 Hot-water heating

As a high-quality alternative to hot air heating, the ALDE hot water heating system with its numerous convectors provides a particularly pleasant warmth. The system is also available with an energy-saving heat exchanger on request (depending on the layout).

Illustrations for example purposes only.



Layouts and technical data

The HYMER ML-T models at a glance.

Technical data

Chassis

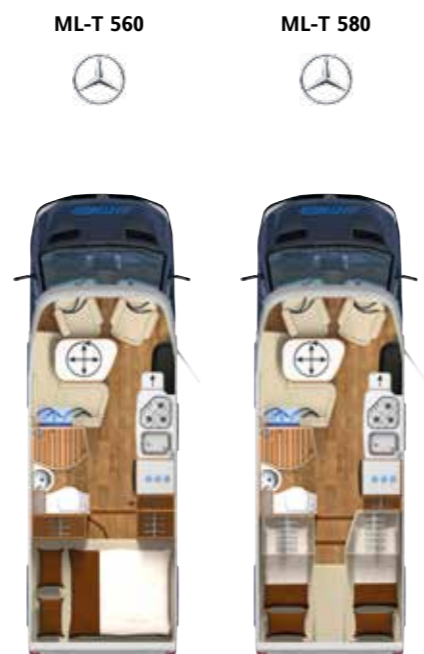

Overall length (cm)	698	698
Overall width (222 cm)	✓	✓
Overall height (290 cm)	✓	✓
Headroom in living area (198 cm)	✓	✓
Mass in running order approx. (kg)	2,940	2,970
Payload approx. (kg) / O	560 / 940 / 1,260	530 / 910 / 1,230
Max. permissible laden mass (kg) / O	3,500 / 3,880 / 4,200	3,500 / 3,880 / 4,200
Berths + O	♣♣ + ♣	♣♣ + ♣

All technical data can be found in the current motorhome price list.

O = Optional extras

Standard chassis:
Mercedes Sprinter 313 CDI



In HYMER motorhomes the overall length and width, laden and unladen mass are optimally adjusted to the Sprinter chassis.

Fabric design & carpets

The interior at a glance.

✓ = Standard equipment ○ = Optional extra



Fabric design	Castello	Charbonnel	Millau	Santorin	Varuna	Martinique	Etna	Cremissimo
HYMER Exsis-t	✓	✓	✓	✓	–	○	○	○
HYMER T-Class CL	✓	✓	✓	✓	–	○	○	○
HYMER T-Class SL	✓	✓	✓	✓	○	○	○	○
HYMER ML-T	✓	✓	✓	✓	–	○	–	○

Paradiso	Tobago	Pebble leather
○	–	○
○	○	○
○	○	○
○	○	○

Carpets	Eclipse	Havanna
	○	○
	○	○
	○	○
	○	○

Textile

Textile leather/textile

Real leather/textile

Real leather

Carpets



“Castello” fabric design



“Santorin” fabric design



“Etna” fabric design



“Paradiso” fabric design (Ecotech/textile)



“Pebble leather” fabric design



“Eclipse” carpet



“Charbonnel” fabric design



“Varuna” fabric design



“Cremissimo” fabric design



“Tobago” fabric design



“Havanna” carpet



“Millau” fabric design



“Martinique” fabric design

HYMER original parts & accessories

A perfect match.



The new HYMER E-Bike

Whether for the campsite, city shopping or more demanding cycling tours, the new HYMER E-Bike gives you infinite mobility. The 20-inch HYMER E-Bike is supplied fully equipped. Among the items included in the price are a large battery (BOSCH GEN 2 Active Line 400 Wh), sprung seat post, Ortlieb bag in HYMER

design with Quick Snap fastening and ABUS combination lock. Besides a dead weight of just 21 kilos, the HYMER E-Bike boasts ergonomic grips, wide tyres, folding pedals, folding handlebars and a battery range of up to 105 km plus LED lights, making it a genuine premium product.

Discover the wide range of innovative solutions available in the categories interior, exterior, chassis system, travel and transportation. With HYMER original accessories, you can rest assured you've made the right choice, i.e. the right fit, impeccable workmanship and original quality.



Lasting protection

The HYMER nano-coating is a high-performance two-component paint sealant. It provides lasting protection for your paintwork and makes it quicker and easier to clean. That way, your vehicle will keep its shine – and its value – for a long time to come.



Well covered

You can tell an original HYMER seat cover from its optimal fit. The covers are machine-washable with a pocket at the back, and are available in beige and graphite.



No more soakings

The high-quality HYMER golf umbrella shakes dry in an instant thanks to its Teflon coating, ready for stowing back in the vehicle.



Windscreen cover

Provides sun protection and privacy. Ultra-light, weather-resistant PVC-coated mesh fabric. Fits perfectly and looks great.



No more detours

Professional, mobile navigation system for motorhomes and caravans from HYMER and Tom-Tom, including integrated ADAC site and camping guide plus free lifetime map updates.



A perfect fit

Cut-to-fit, high-quality front seat floor mats made from polypropylene tufted velour with nubuck edging. Stamped with the Original HYMER branding.

Illustrations for example purposes only.

We are constantly developing innovative new solutions for our customers. You can find the full range at www.hymer-original-parts.com. Easy to use, informative and relevant to your vehicle. Your HYMER dealer will be happy to advise you.

You can find the full range of HYMER original parts & accessories on the internet at: www.hymer-original-parts.com

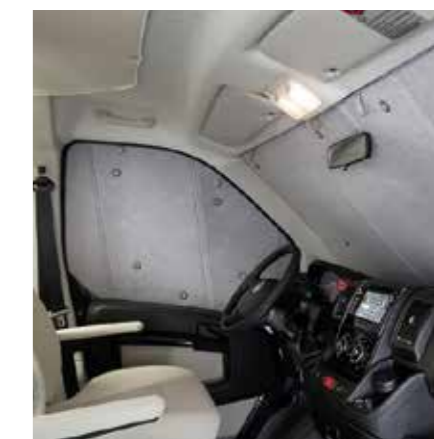
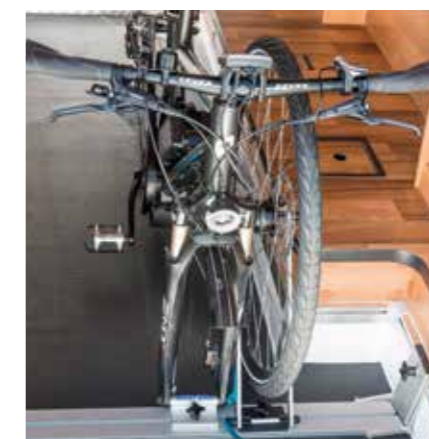
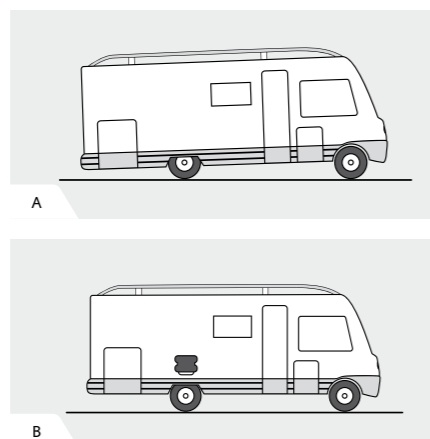
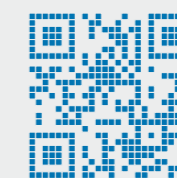

An individual touch

With their simple elegance and huge load-bearing capacity, HYMER aluminium rims by Goldschmitt not only enhance the appearance of your Hypermobil, but are also ideal for increasing the weight rating.

On an even keel

(A) If your HYMER motorhome is exposed to too much strain, e.g. due to heavy loads, this can lead to the situation pictured here. (B) The additional air springs from Goldschmitt raise the rear of the vehicle to ensure adequate suspension travel.

Firm, level standing

The handy corner steadies at the rear of the vehicle can be used to stabilise the motorhome when parked. This prevents unwanted bouncing of the suspension, particularly in the sleeping area. The steadies can also compensate for any slight unevenness of the ground.

All on board ...

... Thanks to the flexible garage space management system specially developed for HYMER and featuring a full-extension heavy-duty slide. That way you can keep the garage well organised and no longer have the hassle of climbing inside for loading and unloading.

Don't forget your bike!

Exclusive bicycle rack system for the HYMER rear garage. Takes just seconds to install. Probably the smallest and lightest bike rack in the motorhome sector, it manages without the usual support rail.

Winterproof

The 3-part interior insulation for the cab consists of an 8 mm thick insulating foam mat which seals tight to the contours of the window. The mats have rubber suction pads for quick assembly and removal.



Wrapped up warm

The new super-soft and extra-large blanket from Zoeppritz in the colour Smoke is washable and dryer-safe.

Like sleeping on air

The new Visco-Elastic foam specially developed for the HYMER mattress topper is air-permeable and moulds to your body at the slightest resistance. This produces a pressure-relieving effect, guaranteeing improved blood circulation and sleeping comfort over longer periods.

Made to measure

You can tell an original HYMER fitted sheet from its optimal fit. Available for all bed versions, the sheet is pleasantly soft to the touch and is washable at 60 degrees and dryer-safe.



Ready for the slopes

The innovative ski compartment is ideal for secure transportation of all your skiing or snowboarding equipment (available from Spring 2015).

Rear vision

The new reversing camera is elegantly integrated into the third brake light and painted in the same colour as the vehicle. Thanks to infra-red sensors, it ensures optimal visibility even at night (available from Spring 2015).



HYMER original parts and accessories are not available direct from the factory, but are ordered and retrofitted exclusively via your HYMER dealer.

Note

This brochure describes the series status at the time of publication. Despite careful checking of the contents, misprints cannot be ruled out. We reserve the right to modify the equipment or make product improvements during the course of the model year. Before signing a sales contract, please ask one of our authorised HYMER dealers about the current product and series status.

Some vehicles are shown with optional extras which are quoted in the current price list and available at extra cost. The decoration shown is not supplied by HYMER. The details of scope of delivery, appearance, performance, dimensions and weights are valid at the time of going to press – deviations within the factory tolerance limits (max +/- 5%) are possible and permissible.

These data comply with European homologation regulations, which may change up to the time of vehicle purchase or delivery. Your HYMER dealer will gladly provide information on any changes and the standard scope of delivery.

Copyright © 2014 HYMER AG

HYMER

HYMER AKTIENGESELLSCHAFT
Postfach 1140
D-88330 Bad Waldsee

www.hymer.com
www.facebook.com/hymerAG

